

**COVERLAM** | **TOP**

# GUÍA TÉCNICA

TECHNICAL MANUAL

ESPAÑOL  
ENGLISH

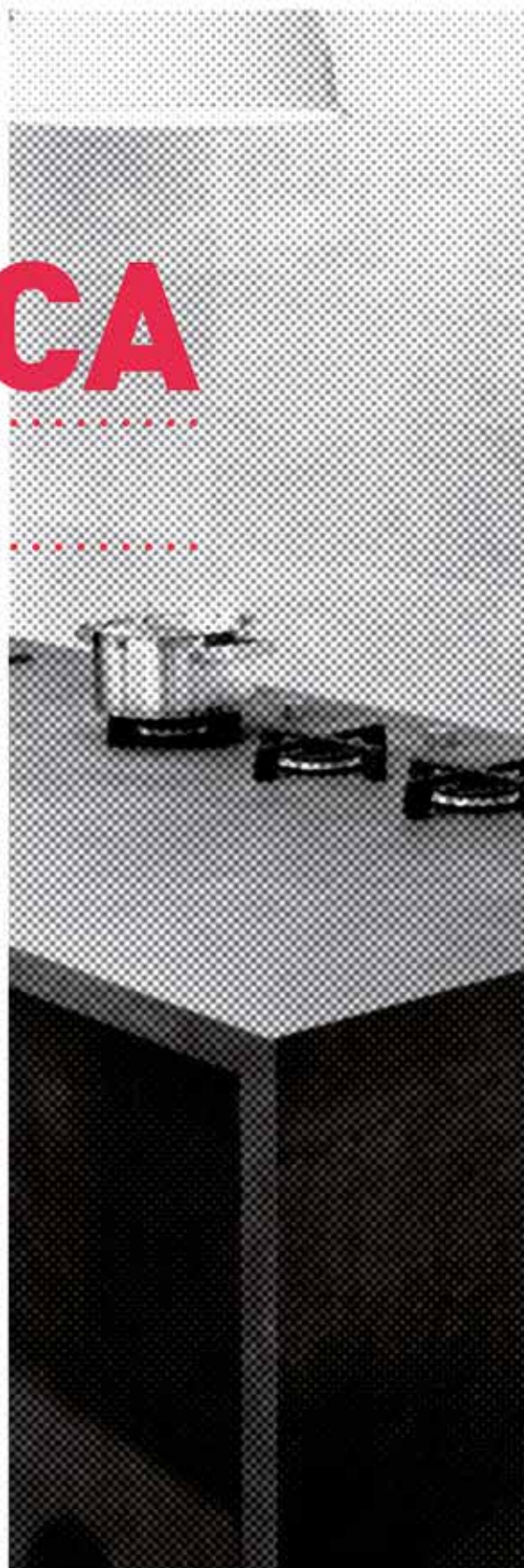

**GRES PANIA**

# COVERLAM | TOP

## TECHNICAL MANUAL

### ÍNDICE INDEX



<b>Producto / Product</b> .....	2
<b>Almacenamiento, manipulación y transporte / Storage, handling and transport</b> .....	20
<b>Control de calidad / Quality control</b> .....	32
<b>Mecanizado / Machining</b> .....	36
<b>Recomendación de Diseño de encimera / Counter design recommendations</b> .....	44
<b>Herramientas / Tools</b> .....	55
<b>Pegado / Bonding</b> .....	56
<b>Limpieza / Stain</b> .....	60
<b>Certificados y Garantía / Certificates and warranty</b> .....	64

**GRES PANIA**

# PRODUCTO

PRODUCT



**PRODUCTO**

## PRODUCT

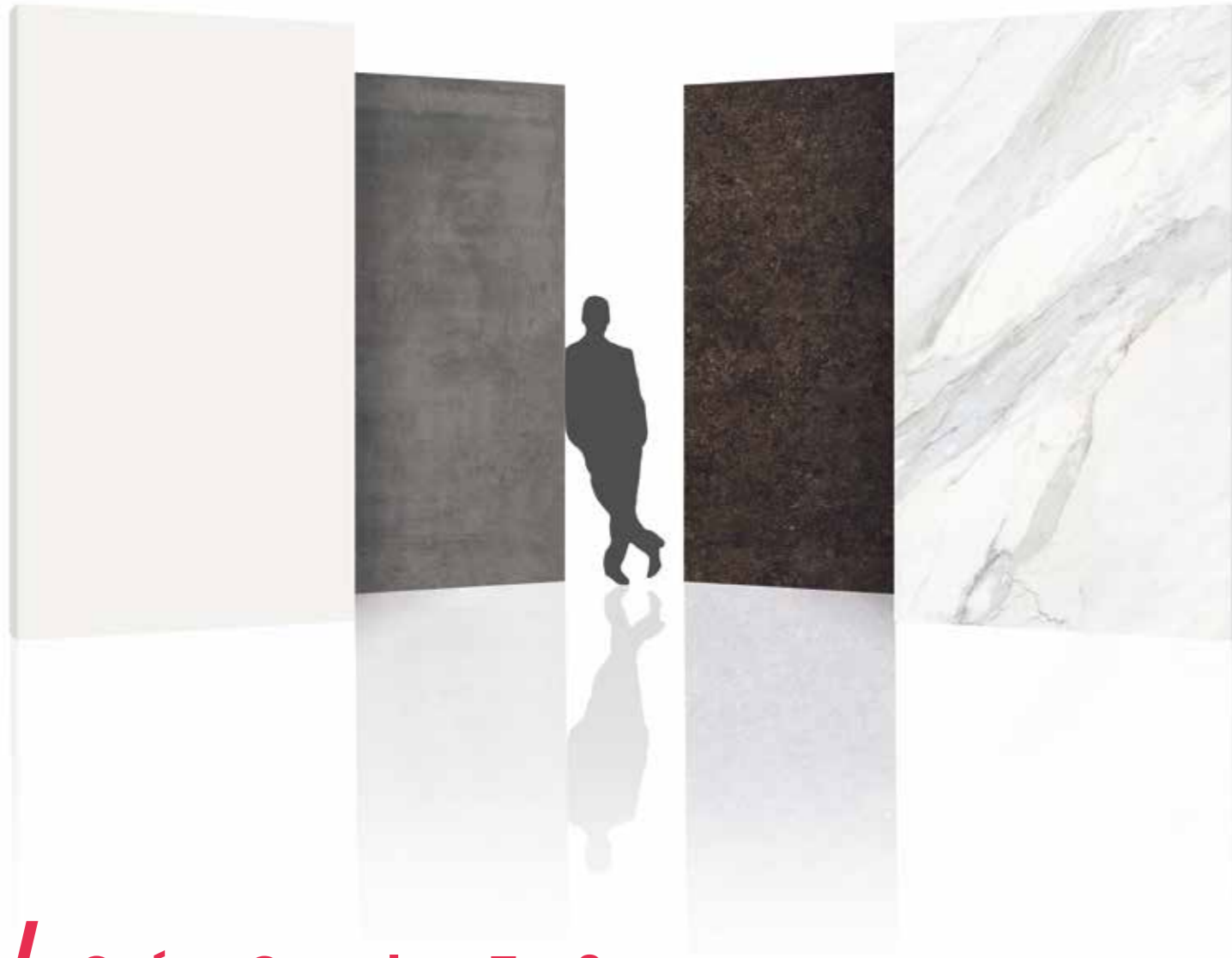

## / ¿Qué es Coverlam Top?

COVERLAM TOP es un innovador producto fabricado CON materias primas naturales que ofrece unas propiedades mecánicas y estéticas superiores a las de cualquier material de recubrimiento convencional.

Gracias a su fácil corte y manipulación, COVERLAM TOP en su formato 1620x3240 mm, 1600x3200 mm Y 1000x3000 mm, y espesores 20 mm, 12 mm y 10,5 mm, se convierte en un material que permite revestir grandes superficies dentro del hogar.

Hoy en día es posible ofrecer acabados ultrarresistentes para: encimeras de cocina, mesas o armarios.

Gracias a su elevada dureza, COVERLAM TOP es capaz de evitar rayaduras y erosiones en encimeras por el uso cotidiano, manteniendo de esta forma su riqueza estética original durante más tiempo.

Asimismo, COVERLAM TOP es capaz de cumplir con las necesidades más exigentes del hogar en cuanto a resistencia térmica, química y a las manchas de humedades. Además gracias a su casi nula porosidad se obtiene una superficie higiénica y antibacteriana que resulta idóneo para la manipulación de alimentos.



## / What is Coverlam Top?

COVERLAM TOP is an innovative product made from natural raw materials with exceptional mechanical and aesthetic properties that surpass those of any conventional tiling material.

With its 1620x3240 mm, 1600x3200 mm and 1000x3000 mm format, and 20 mm, 12 mm and 10,5 mm thickness, COVERLAM TOP is easy to cut and handle, making it a suitable material for covering large areas inside the home.

It is now possible to achieve ultra-resistant finishes for kitchen countertops, tables or cupboards.

Thanks to its great strength, COVERLAM TOP is resistant to everyday wear and scratches on countertops, thus maintaining its original aesthetic vibrancy for longer.

COVERLAM TOP can also meet the most demanding needs of the home in terms of resistance to heat, chemicals and damp stain. In addition, thanks to its minimal porosity, it is a hygienic, antibacterial surface ideal for food preparation.

# FORMATOS Y ESPESORES

FORMAT AND THICKNESS

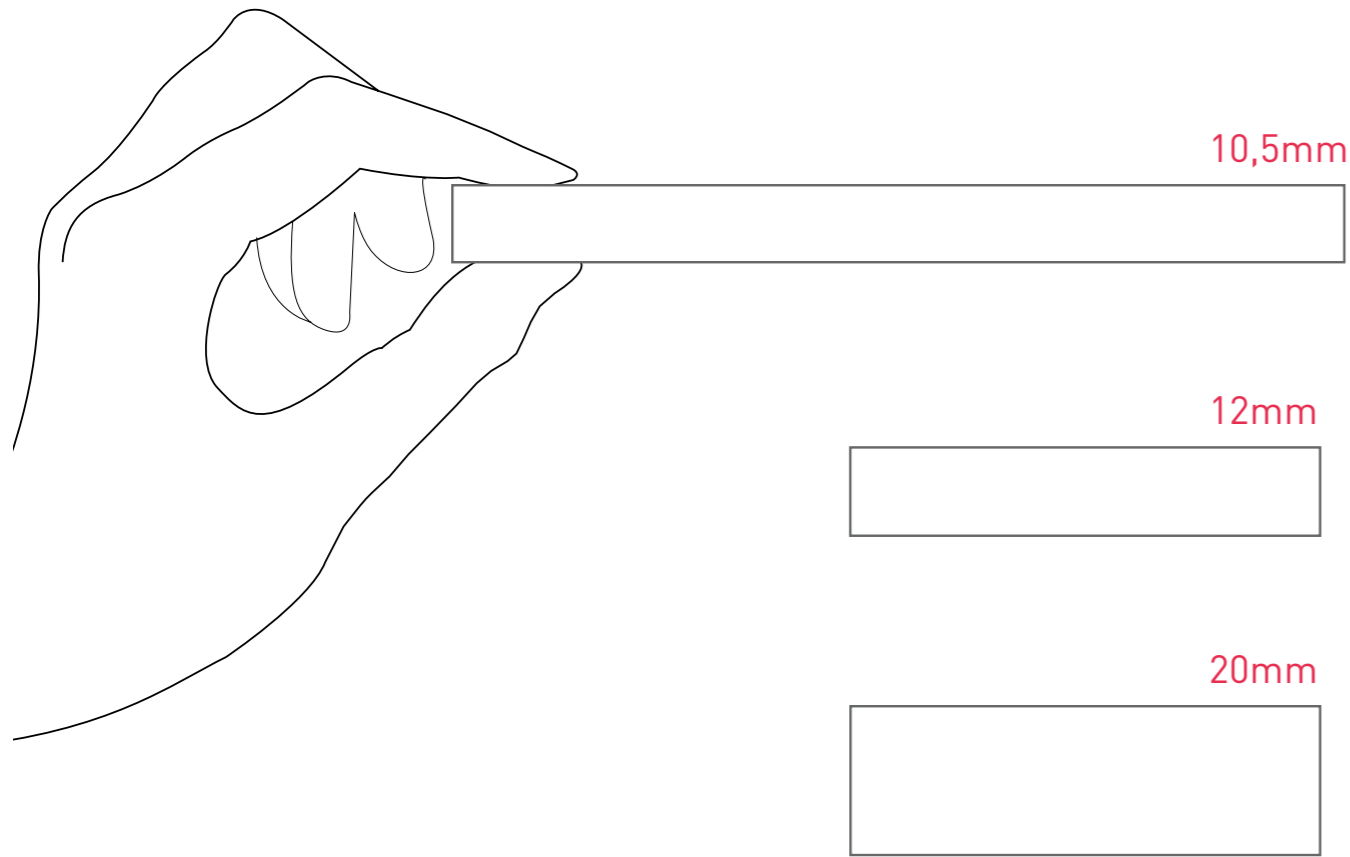

	FORMATOS / FORMAT		
	1620x3240 mm	1000x3000 m	1600x3200 mm
10,5mm		•	
12mm	•		
20mm			•
ESPESORES / THICKNESS			



**COLECCIONES**  
COLLECTIONS

	1620X3240 MM 12MM	1000X3000 MM 10,5MM	1600X3200 MM 20MM
ARTIC NATURAL Y PULIDO gris, antracita	•	•	
BASALTINA negro, beige	•	•	
BASIC NATURAL Y PULIDO nieve		•	
BASIC NATURAL negro	•	•	•
BASIC NATURAL marfil, taupé, cemento	•	•	
BASIC NATURAL blanco	•		•
BASIC PULIDO blanco	•		
BLUE STONE gris y negro	•	•	
CALACATA NATURAL	•	•	•
CALACATA PULIDO	•	•	
CALACATA BOOK NATURAL y PULIDO		•	
CAMARGE blanco, arena	•	•	
CARRARA NATURAL y PULIDO	•	•	
CONCRETE NATURAL y PULIDO gris	•	•	
CORINTO NATURAL	•	•	
CUARZO RENO PULIDO	•	•	
DISTRITO aluminio, marfil, iron	•	•	
DUOMO NATURAL y PULIDO	•	•	
ESTATUARIO BOOK NATURAL y PULIDO	•	•	
ICEBERG NATURAL y PULIDO	•	•	
IRATI nogal, abeto, encina, roble	• (no roble)	•	
LAVA corten, iron	•	•	
MOMA arena, gris	•	•	
NERO ARDI NATURAL	•	•	
PALADIO NATURAL y PULIDO	•	•	
PORFIDO sand, brown, graphite, taupe	•	•	• (no taupe)
SILK NATURAL y PULIDO blanco y gris		•	
TITAN cemento, antracita	•	•	•
VIELLA	•		

/ MÁRMOLES  
MARBLES

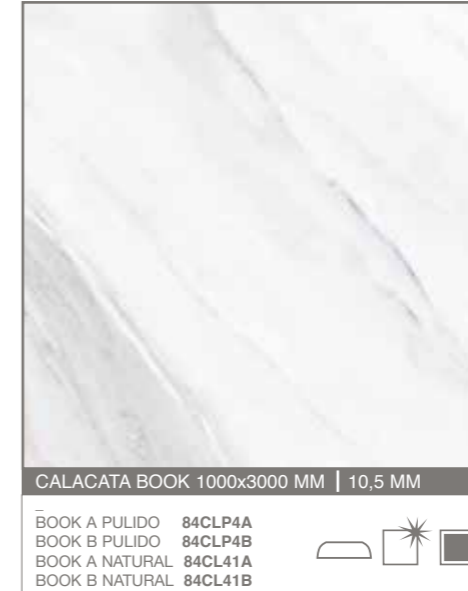

/ MÁRMOLES  
MARBLES



CARRARA 1620x3240 MM | 12 MM  
 NATURAL 88RR46S  
 PULIDO 88RR46P  
 CARRARA 1000x3000 MM | 10,5 MM  
 NATURAL 84RR41S  
 PULIDO 84RR4PS



DUOMO 1620x3240 MM | 12 MM  
 NATURAL 88DU46S  
 PULIDO 88DU46P  
 DUOMO 1000x3000 MM | 10,5 MM  
 NATURAL 84DU41S  
 PULIDO 84DU4PS



ARTIC GRIS 1620x3240 MM | 12 MM  
 NATURAL 88RC36S  
 PULIDO 88RC36P  
 ARTIC GRIS 1000x3000 MM | 10,5 MM  
 NATURAL 84RC31S  
 PULIDO 84RC3PS

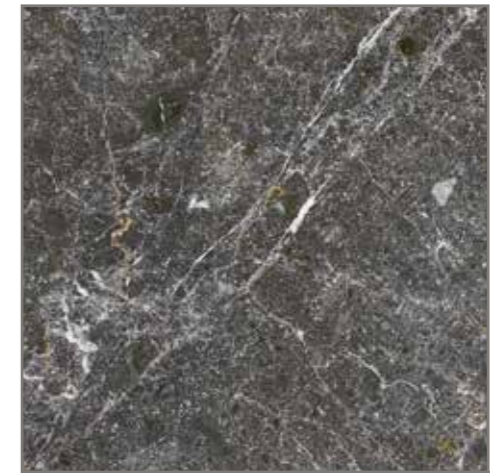

ARTIC ANTRACITA 1620x3240 MM | 12 MM  
 NATURAL 88RC66S  
 PULIDO 88RC66P  
 ARTIC ANTRACITA 1000x3000 MM | 10,5 MM  
 NATURAL 84RC61S  
 PULIDO 84RC6PS

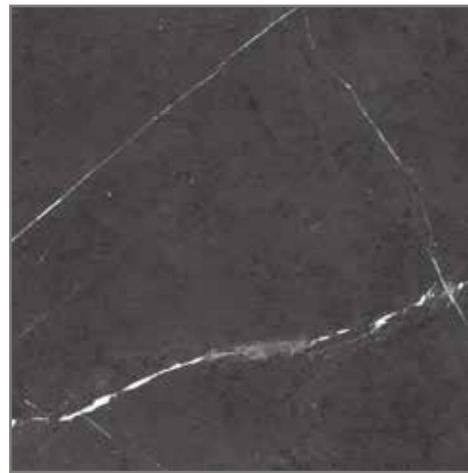

PALADIO 1620x3240 MM | 12 MM  
 NATURAL 88PD26S  
 PULIDO 88PD26P  
 PALADIO 1000x3000 MM | 10,5 MM  
 NATURAL 84PD21S  
 PULIDO 84PD2PS

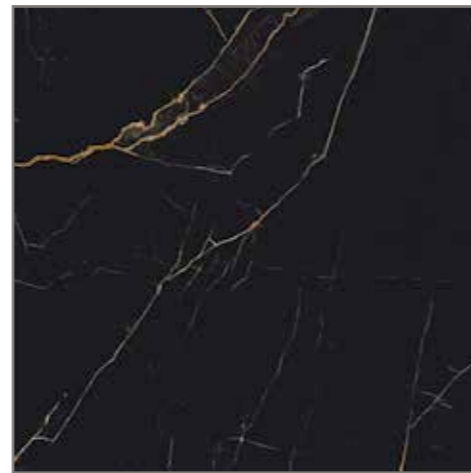

NERO ARDI 1620x3240 MM | 12 MM  
 NATURAL 88NH96S  
 NERO ARDI 1000x3000 MM | 10,5 MM  
 NATURAL 84NH91S

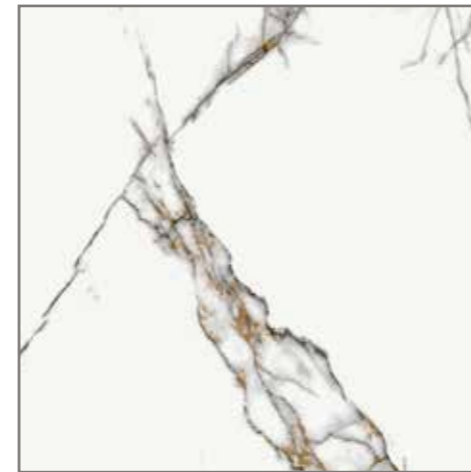

ICEBERG 1620x3240 MM | 12 MM  
 NATURAL 88I146S  
 PULIDO 88I146P  
 ICEBERG 1000x3000 MM | 10,5 MM  
 NATURAL 84I141S  
 PULIDO 84I14PS



CORINTO 1620x3240 MM | 12 MM  
 NATURAL 88IA46S  
 CORINTO 1000x3000 MM | 10,5 MM  
 NATURAL 84IA41S



SILK BLANCO 1000x3000 MM | 10,5 MM  
 NATURAL 84SL41S  
 PULIDO 84SL4PS



SILK GRIS 1000x3000 MM | 10,5 MM  
 NATURAL 84SL31S  
 PULIDO 84SL3PS



CUARZO RENO 1620x3240 MM | 12 MM  
 PULIDO 88CN36P  
 CUARZO RENO 1000x3000 MM | 10,5 MM  
 PULIDO 84CN3PS

/ CEMENTOS  
CEMENTS



TITAN ANTRACITA 1600x3200 MM | 20 MM  
 ANTRACITA 90TI60S  
 TITAN ANTRACITA 1620x3240 MM | 12 MM  
 ANTRACITA 88TI66S  
 TITAN ANTRACITA 1000x3000 MM | 10,5 MM  
 ANTRACITA 84TI61S



MOMA ARENA 1620x3240 MM | 12 MM  
 ARENA 88MM06S  
 MOMA ARENA 1000x3000 MM | 10,5 MM  
 ARENA 84MM01S



TITAN CEMENTO 1600x3200 MM | 20 MM  
 CEMENTO 90TI10S  
 TITAN CEMENTO 1620x3240 MM | 12 MM  
 CEMENTO 88TI16S  
 TITAN CEMENTO 1000x3000 MM | 10,5 MM  
 CEMENTO 84TI11S



MOMA GRIS 1620x3240 MM | 12 MM  
 GRIS 88MM36S  
 MOMA GRIS 1000x3000 MM | 10,5 MM  
 GRIS 84MM31S



CONCRETE GRIS 1620x3240 MM | 12 MM  
 NATURAL 88CO36S  
 PULIDO 88CO36P  
 CONCRETE GRIS 1000x3000 MM | 10,5 MM  
 NATURAL 84CO31S  
 PULIDO 84CO3PS

/ MONOCOLOR  
MONOCOLOR

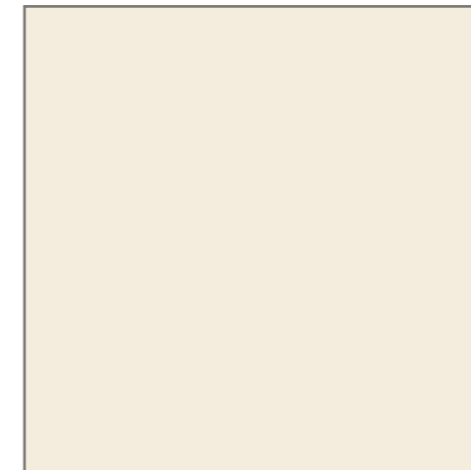

BASIC MARFIL 1620x3240 MM | 12 MM  
 MARFIL 88BA76S  
 BASIC MARFIL 1000x3000 MM | 10,5 MM  
 MARFIL 84BA71S

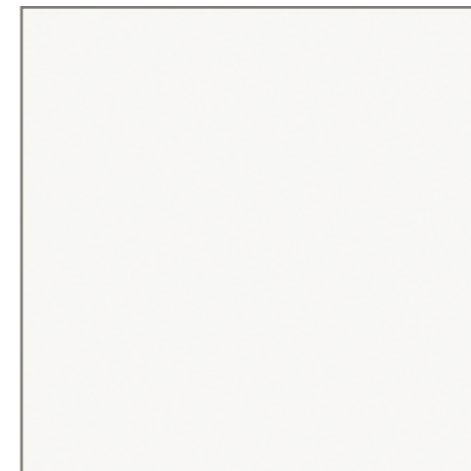

BASIC NIEVE 1000x3000 MM | 10,5 MM  
 NATURAL 84BA01S  
 PULIDO 84BA0PS



BASIC NEGRO 1600x3200 MM | 20 MM  
 NATURAL 90BA90S  
 BASIC NEGRO 1620x3240 MM | 12 MM  
 NATURAL 88BA96S  
 BASIC NEGRO 1000x3000 MM | 10,5 MM  
 NATURAL 84BA91S



BASIC TAUPÉ 1620x3240 MM | 12 MM  
 TAUPÉ 88BA86S  
 BASIC TAUPÉ 1000x3000 MM | 10,5 MM  
 TAUPÉ 84BA81S

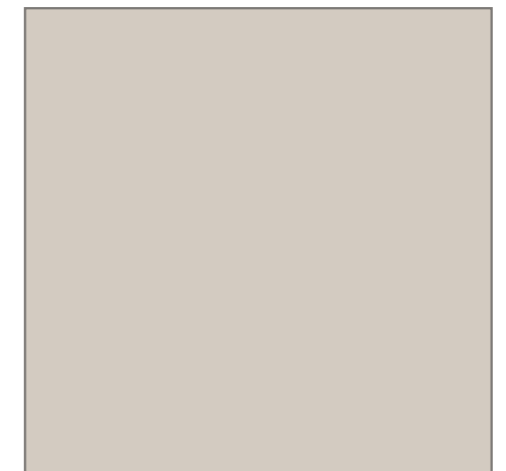

BASIC CEMENTO 1620x3240 MM | 12 MM  
 NATURAL 88BA16S  
 BASIC CEMENTO 1000x3000 MM | 10,5 MM  
 NATURAL 84BA11S

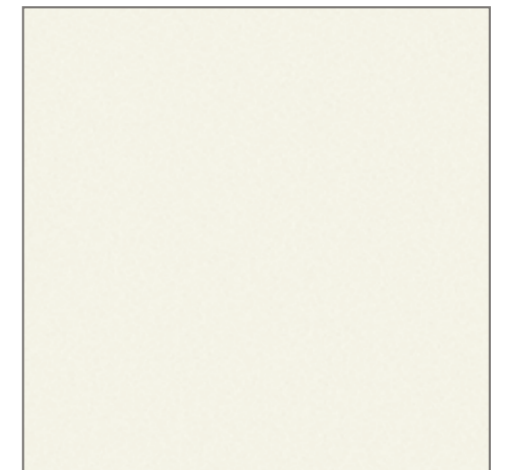

BASIC BLANCO 1600x3200 MM | 20 MM  
 NATURAL 90BA40S  
 BASIC BLANCO 1620x3240 MM | 12 MM  
 NATURAL 88BA46S  
 PULIDO 88BA46P



/ PIEDRAS  
STONES



CAMARGUE ARENA 1620x3240 MM | 12 MM  
 ARENA 88RG76S



CAMARGUE ARENA 1000x3000 MM | 10,5 MM  
 ARENA 84RG71S



CAMARGUE BLANCO 1620x3240 MM | 12 MM  
 BLANCO 88RG46S



CAMARGUE BLANCO 1000x3000 MM | 10,5 MM  
 BLANCO 84RG41S



PÓRFIDO 1600x3200 MM | 20 MM  
 SAND 90PF70S

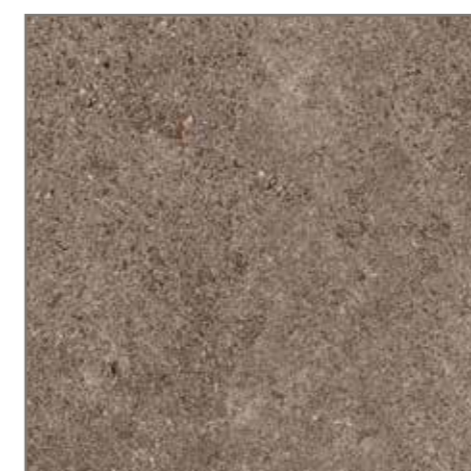

PÓRFIDO 1000x3000 MM | 10,5 MM  
 SAND 84PF71S



PÓRFIDO 1000x3000 MM | 10,5 MM  
 TAUPE 84PF81S



BASALTINA BEIGE 1620x3240 MM | 12 MM  
 BEIGE 88BN76S



BASALTINA BEIGE 1000x3000 MM | 10,5 MM  
 BEIGE 84BN71S



BASALTINA NEGRO 1620x3240 MM | 12 MM  
 NEGRO 88BN96S



BASALTINA NEGRO 1000x3000 MM | 10,5 MM  
 NEGRO 84BN 91S



PÓRFIDO 1600x3200 MM | 20 MM  
 BROWN 90PF20S



PÓRFIDO 1000x3000 MM | 10,5 MM  
 BROWN 84PF21S



PÓRFIDO 1600x3200 MM | 20 MM  
 GRAPHITE 90PF90S



PÓRFIDO 1000x3000 MM | 10,5 MM  
 GRAPHITE 84PF91S



BLUE STONE 1620x3240 MM | 12 MM  
 GRIS 88BS36S



BLUE STONE 1000x3000 MM | 10,5 MM  
 GRIS 84BS31S



BLUE STONE 1620x3240 MM | 12 MM  
 NEGRO 88BS96S



BLUE STONE 1000x3000 MM | 10,5 MM  
 NEGRO 84BS91S



VIELLA 1000x3000 MM | 10,5 MM  
 GRIS 84V131S

/ METAL  
METALS



LAVA CORTEN 1620x3240 MM | 12 MM  
CORTEN 88LV06S   

LAVA CORTEN 1000x3000 MM | 10,5 MM  
CORTEN 84LV01S   



LAVA IRON 1620x3240 MM | 12 MM  
IRON 88LV96S   

LAVA IRON 1000x3000 MM | 10,5 MM  
IRON 84LV91S   



DISTRITO ALUMINIO 1620x3240 MM | 12 MM  
ALUMINIO 88DS36S  

DISTRITO ALUMINIO 1000x3000 MM | 10,5 MM  
ALUMINIO 84DS31S  



DISTRITO MARFIL 1620x3240 MM | 12 MM  
MARFIL 88DS46S  

DISTRITO MARFIL 1000x3000 MM | 10,5 MM  
MARFIL 84DS41S  



DISTRITO IRON 1620x3240 MM | 12 MM  
IRON 88DS96S  

DISTRITO IRON 1000x3000 MM | 10,5 MM  
IRON 84DS91S  

/ MADERAS  
WOODS



IRATI ABETO 1620x3240 MM | 12 MM  
ABETO 88IR46S  

IRATI ABETO 1000x3000 MM | 10,5 MM  
ABETO 84IR41S  



IRATI ENCINA 1620x3240 MM | 12 MM  
ENCINA 88IR16S  

IRATI ENCINA 1000x3000 MM | 10,5 MM  
ENCINA 84IR11S  



IRATI NOGAL 1620x3240 MM | 12 MM  
NOGAL 88IR96S  

IRATI NOGAL 1000x3000 MM | 10,5 MM  
NOGAL 84IR91S  



IRATI ROBLE 1000x3000 MM | 10,5 MM  
ROBLE 84IR71S  

/SIMBOLOGÍA SYMBOLS



MATE  
MATT



RELIEVE  
RELIEF



BRILLO  
GLOSSY



NO RECTIFICADO  
NON-RECTIFIED

## VENTAJAS

### BENEFITS



LIGEREZA  
LIGHTWEIGHT



RESISTENCIA A LA HELADA  
FROST RESISTANCE



RESISTENCIA AL IMPACTO  
IMPACT RESISTENCE

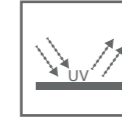

RESISTENCIA A LOS RAYOS UV  
RESISTANCE TO UV RAYS



SUPERFICIE HIGIÉNICA Y RESISTENTE AL RAYADO  
HYGIENIC AND SCRATCH RESISTANCE



RESISTENCIA QUÍMICA  
CHEMICAL RESISTANCE



RESISTENCIA AL DESGASTE  
WEAR RESISTANCE



RESISTENCIA A LA FLEXIÓN  
FLEXURAL STRENGTH



SUPERFICIE IMPERMEABLE  
WATERPROOF SURFACE



RESISTENCIA AL FUEGO Y AL CALOR  
RESISTANCE TO FIRE AND HEAT



RESISTENCIA A LAS MANCHAS  
STAIN RESISTANCE



RESPETUOSO CON EL MEDIO AMBIENTE  
RESPECTFUL OF THE ENVIRONMENT



# ALMACENAMIENTO, MANIPULACIÓN Y TRANSPORTE

STORAGE, HANDLING AND TRANSPORT

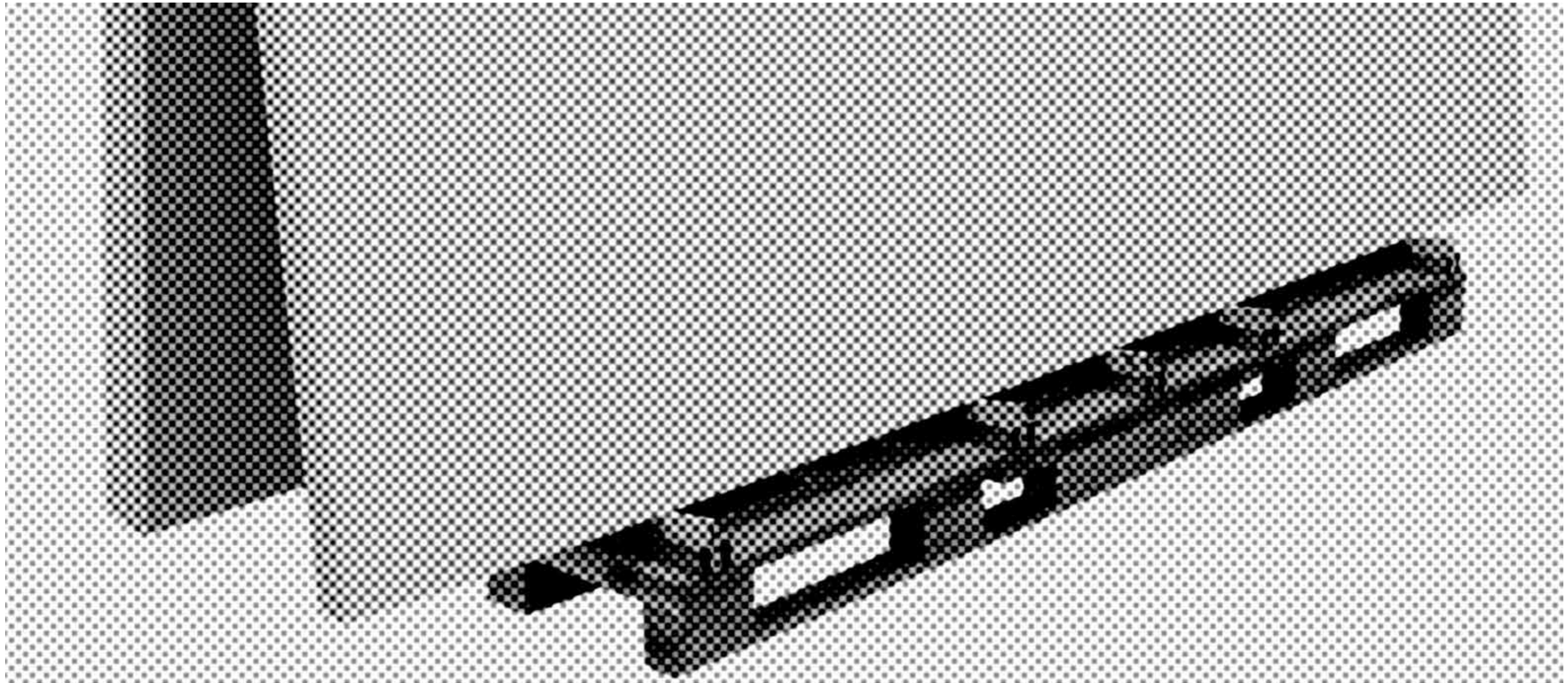

## ALMACENAMIENTO MANIPULACIÓN Y TRANSPORTE

### STORAGE, HANDLING AND TRANSPORT

#### ALMACENAMIENTO

#### STORAGE

Coverlam Top presenta 2 tipos distintos de embalaje dependiendo de las dimensiones y espesor del tablero. En el caso de los tableros de 3x1 metros y 10,5mm de espesor, estos vienen en cajones de madera apilables.

COVERLAM TOP offers 2 distinct types of packing, depending on the dimensions and thickness of the panel. 10.5mm-thick 3000x1000mm panels come in stackable wooden crates.



Superficie Tablero Panel surface area	3 m <sup>2</sup>
Peso Tablero Panel weight	78,57 Kg
Peso por m2 Panel weight/m2	26,19 Kg/m <sup>2</sup>
Tableros por cajón Panels per crate	7
Peso del cajón Empty crate weight	70 Kg
Peso del cajón completo Weight of fully loaded crate	620 Kg
Dimensiones del cajón Crate dimensions	1,1x3,13x0,2 m

En el caso de los tableros de 3,24x1,62 metros y 12mm de espesor, y de 3,2x1,60 metros y 20mm de espesor estos vienen en caballetes metálicos.

12mm-thick 3240x1620 mm and 20mm-thick 3200x1600 mm panels come in metal A-frame pallets.



	12 mm	20 mm
Superficie Tablero Panel surface area	5,25 m <sup>2</sup>	5,12 m <sup>2</sup>
Peso Tablero Panel weight	157 Kg	255 Kg
Peso por m2 Weight/m2	31,6 Kg/m <sup>2</sup>	50,8 Kg/m <sup>2</sup>
Tableros por caballete Slabs per A-frame pallet	20	14
Peso del caballete Weight of the A-frame pallet	170 Kg	170 Kg
Peso del caballete completo Weight of the fully-loaded A-frame pallet	3.310 Kg	3.740 Kg
Dimensiones del caballete A-frame pallet dimensions	0,76x3,28x1,84 m	

Las tablas más pequeñas nunca deben quedar entre las tablas grandes.

The smaller panels should never be placed between the large panels.

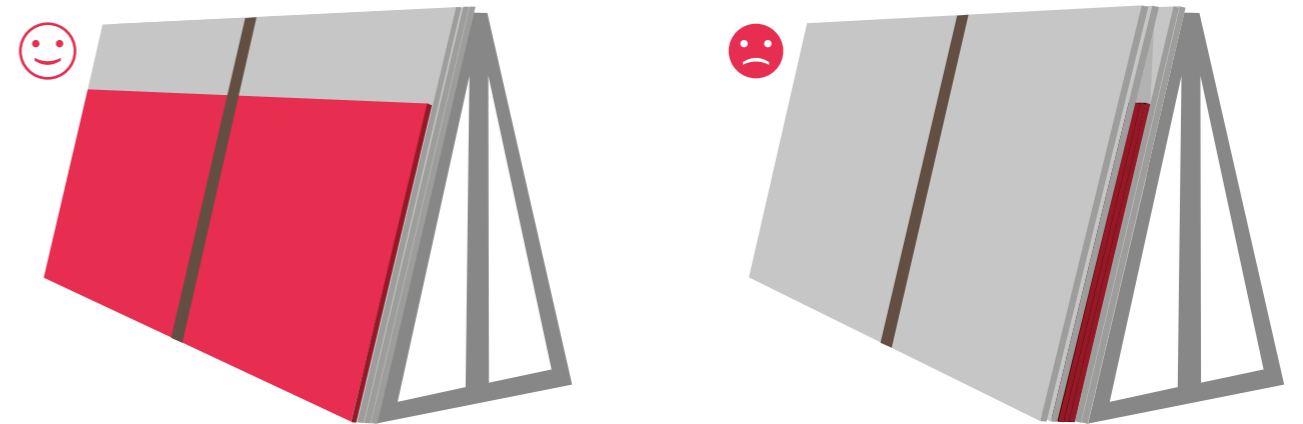

Los caballetes deben poder recoger toda la superficie de los tableros y los flejes no deberán apretarse excesivamente para evitar romper las piezas.

The A-frame pallets should be able to accommodate the entire surface area of the panels and the strapping should not be excessively tight to avoid breakages.

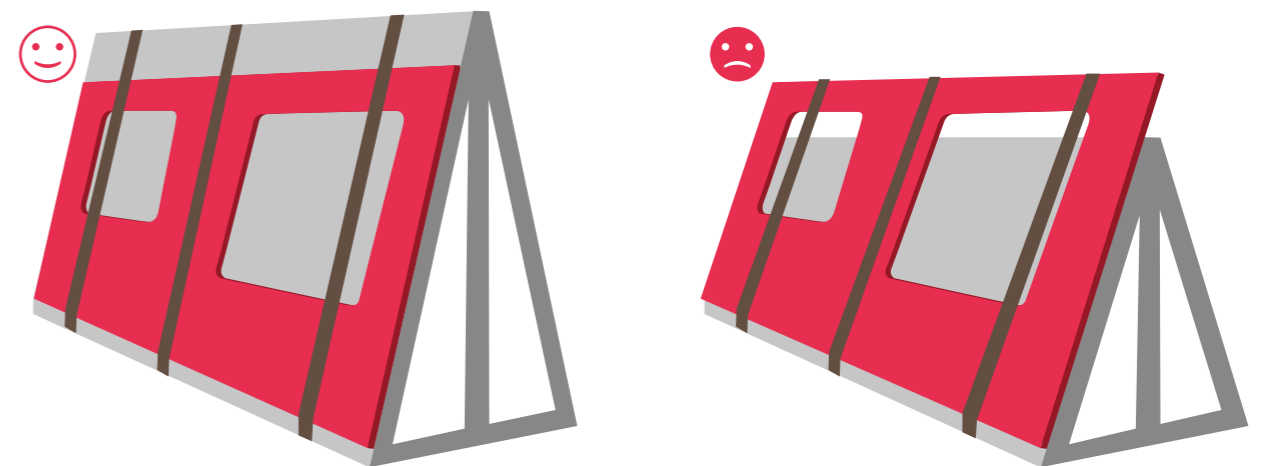

**ALMACENAMIENTO MANIPULACIÓN Y TRANSPORTE**

## STORAGE, HANDLING AND TRANSPORT

**MANIPULACIÓN**

## HANDLING

**MANUAL / MANUAL HANDLING**

En cualquier caso el desplazamiento y el transporte de los tableros se realizará con estos en posición vertical y, tras la realización de agujeros, estos se posicionarán en la parte superior.

The panels should always be moved and transported in a vertical position after drilling holes, which should be located in the upper part.

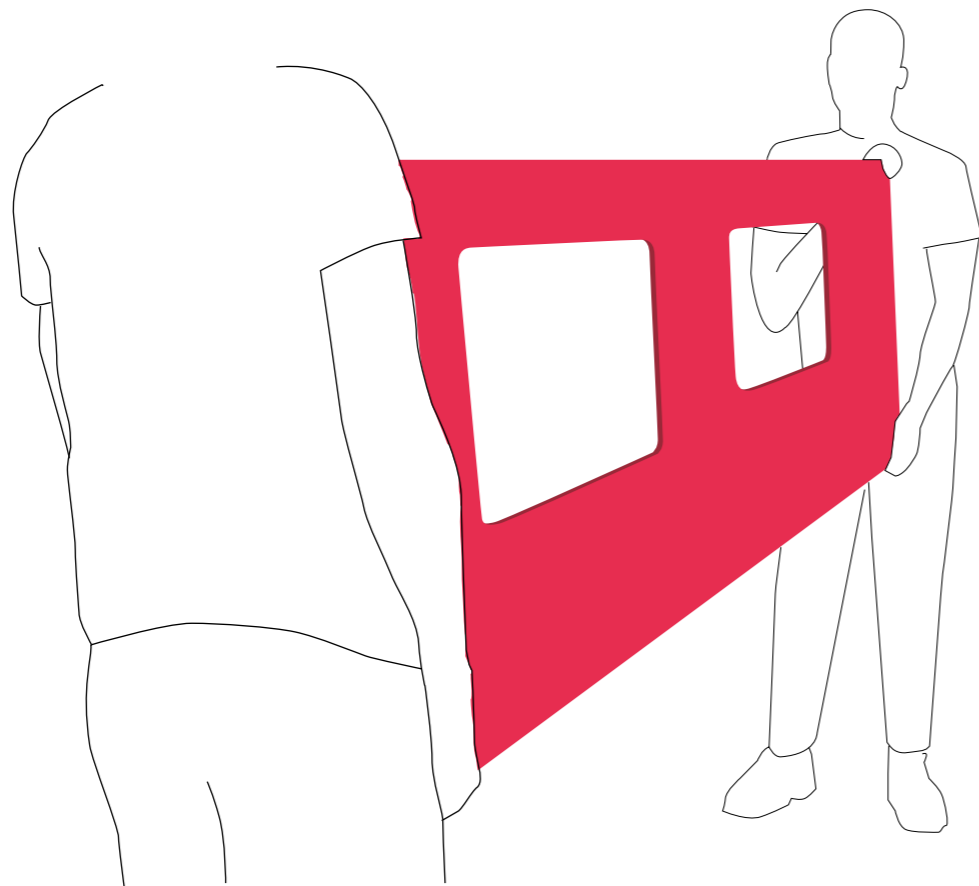

Agujeros siempre en la parte superior  
Holes always in the upper part

Coverlam Top se puede manipular con un puente grúa o una carretilla elevadora con eslingas.  
COVERLAM TOP can be handled using a bridge crane or a forklift with lifting slings.

**CARRETILLA CON ESLINGAS / FORKLIFT WITH LIFTING SLINGS**

Se recomienda no transportar más de un tablero a la vez con este método y si no es posible estas eslingas deben ser de lona.

If using this method, we recommend transporting no more than one panel at a time but if this is not feasible, then lifting slings should be made of canvas.



En ningún caso las eslingas metálicas están recomendadas.  
Under no circumstances are metal lifting slings recommended.

**ALMACENAMIENTO MANIPULACIÓN Y TRANSPORTE**

## STORAGE, HANDLING AND TRANSPORT

**MANIPULACIÓN**

## HANDLING

**PUENTE GRÚA / BRIDGE CRANE**

Prestar atención a la manipulación de los tableros para evitar roturas, para ello el movimiento debe realizarse sin cambios bruscos de dirección y cuidadosamente.

El contacto entre las pinzas metálicas y las piezas debe realizarse a través de un material blando.

Pay careful attention when handling the panels to prevent breakages. They should be moved with great care and without any sudden change of direction. A soft material should be used for padding where there is any direct contact between the metal clamp and the pieces.

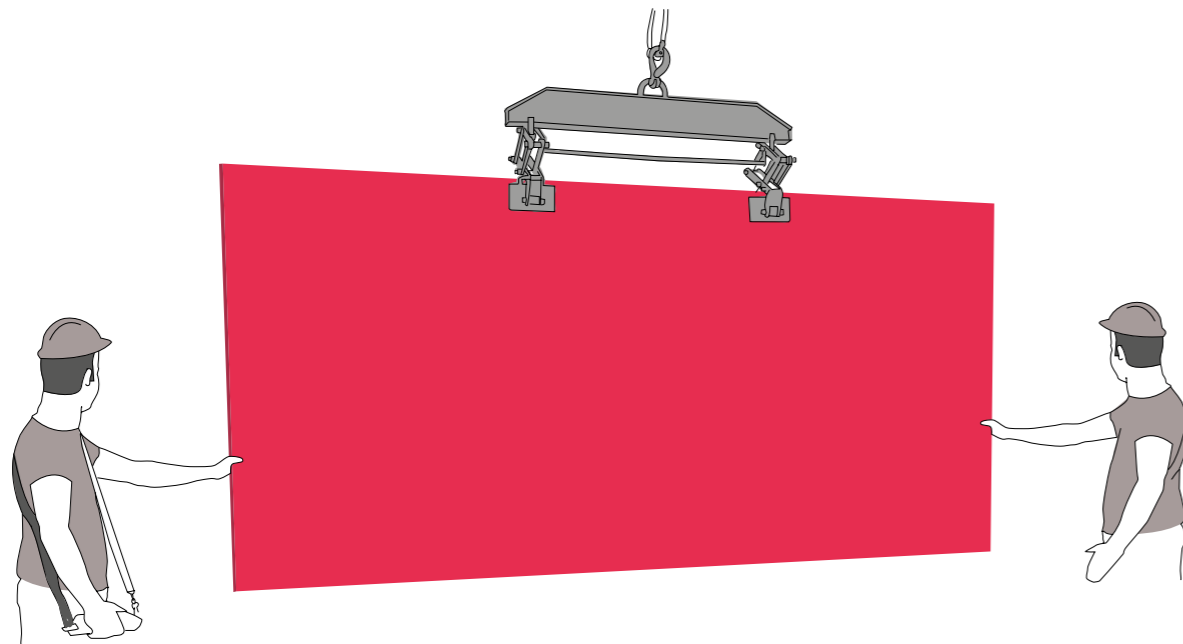

En el caso de no disponer de pinzas metálicas se debe hacer uso de tablones de madera que abarquen la longitud larga del tablero, cogiéndolo con gatos.

If no metal clamps are available, wooden planks should be placed along the length of the panel, and held in place using standard screw clamps.

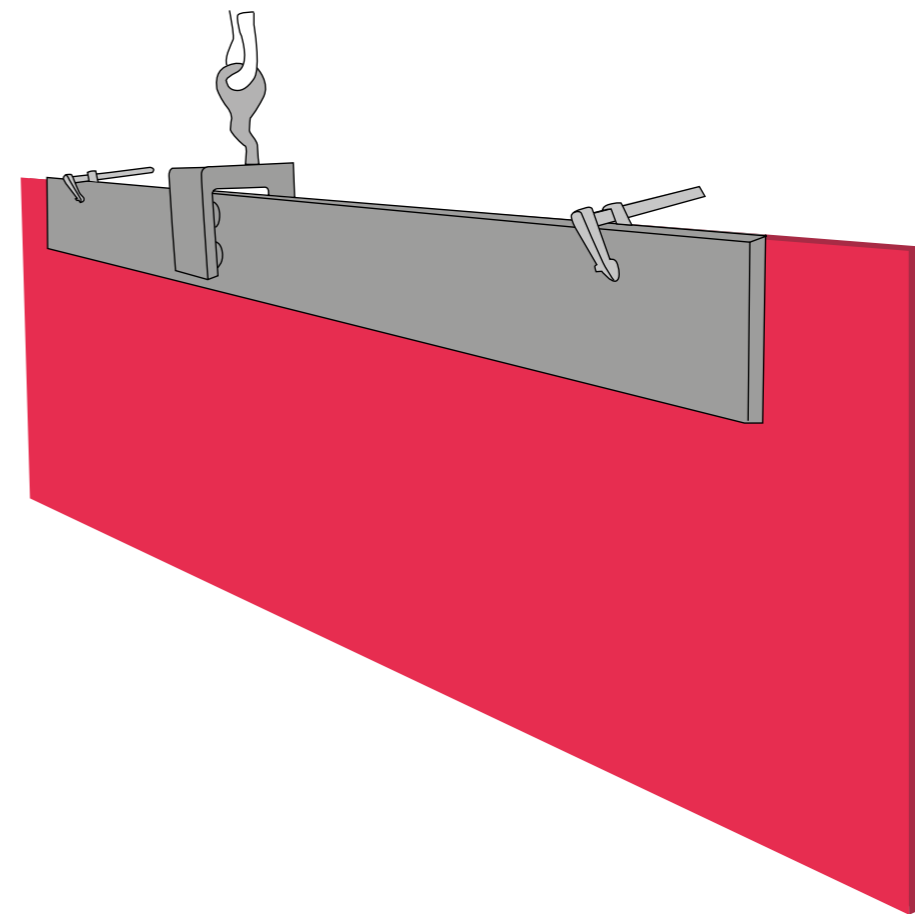

Transportar siempre una pieza como máximo y aquellas con plástico protector, retirarlo previamente.  
Always transport a maximum of one piece at a time, and if any are wrapped in a layer of protective plastic, remove it beforehand.

**ALMACENAMIENTO MANIPULACIÓN Y TRANSPORTE**

## STORAGE, HANDLING AND TRANSPORT

**TRANSPORTE**

## TRANSPORT

**CARRETILLA ELEVADORA / FORKLIFT TRUCK**

Previo al transporte, el operario debe comprobar que las piezas están aseguradas al caballete con los flejes apropiados y que la carretilla elevadora tiene la capacidad de carga necesaria.

En el caso de caballetes, estos deben ser cargados simétricamente antes de ser transportados por carretilla.

Prior to transporting, the operator should check that the pieces are secured to the A-frame pallets using the appropriate strapping and that the forklift truck has the necessary load capacity.

A-frame pallets should be evenly loaded on both sides prior to being transported by forklift.

Para el transporte de los caballetes por el lado largo, es necesario disponer de una carretilla de 4.500 kg de capacidad de carga.

To transport the A-frame pallets lengthwise, the forklift truck requires a load capacity of 4,500 kg.

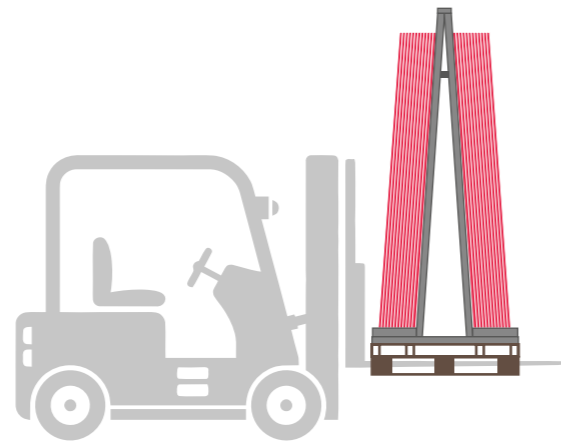

En el caso de disponer de horquillas con un largo de al menos 2,80m y una carretilla de 5.000kg de capacidad, se podrá transportar de la siguiente manera:

If the forks are at least 2.80m long and the forklift has a load capacity of 5,000 kg, they can be transported in the following way:

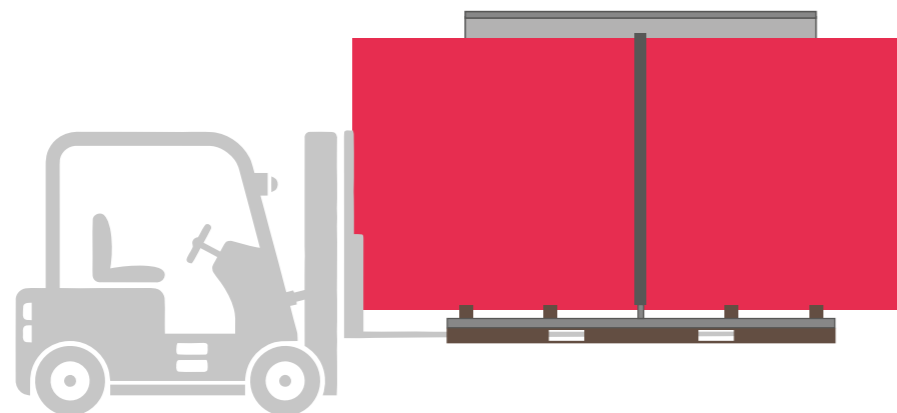

Para levantar y desplazar bandejas de placas de 1000x3000mm. Con carretillas elevadoras o grúas de obra, es importante coger las bandejas centradas por el lado largo.

To lift and move trays containing 1000x3000mm panels. When using forklift trucks or construction cranes, it is important that trays are lifted in the middle of the long side.



En el caso de coger las bandejas por el lado corto es necesario utilizar horquillas con una longitud mínima de 2,5m

When lifting the trays on their short side, forks must be a minimum length of 2.5m.



Se recomienda utilizar palas de al menos 1,20m de longitud en la carretilla para manipular correctamente las bandejas.

We recommend using forks at least 1.20m long on the forklift to be able to pick the trays up properly.



# ALMACENAMIENTO MANIPULACIÓN Y TRANSPORTE

## STORAGE, HANDLING AND TRANSPORT

### TRANSPORTE

#### TRANSPORT

#### TRANSPORTE EN CAMIÓN / TRUCK TRANSPORT

El proceso de carga o descarga de los caballetes en un camión estándar de 13,50m debe realizarse según el esquema inferior:

The loading/unloading of the A-frame pallets onto/off a standard 13.50m truck should be carried out according to the diagram below:

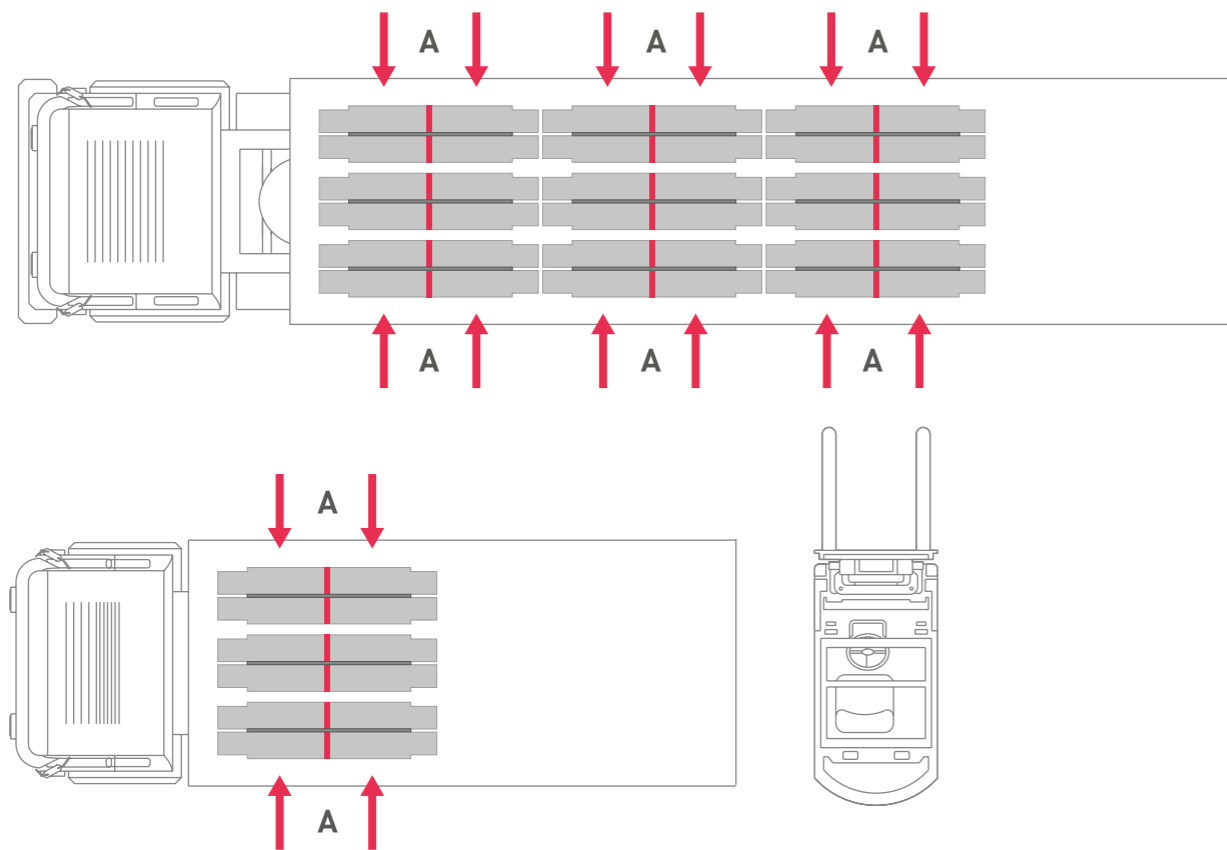

Una vez ubicado en el camión, se deberá comprobar que el material está estable y asegurado. Tras la descarga en el lugar de trabajo, el transporte de los caballetes con la carretilla elevadora debe ser con el caballete en la posición más baja posible.

Once located on the truck, a check should be carried out to ensure the material is stable and secured. Following unloading at the work site, transporting of the A-frame pallets using the forklift truck should be carried out with the A-frame pallet in the lowest possible position.

En el caso de la carga de contenedores, será necesario trabajar con horquillas de al menos 2,80m de largo. La capacidad mínima de la trapaleta o una carretilla elevadora par la carga de contenedores debe ser 5.000 Kg.

For the loading of containers, forks should have a minimum length of 2.80m. The minimum load capacity of the pallet truck or forklift truck used to load containers should be 5,000 Kg.

#### CONTENEDOR 20' CONTAINER 20'

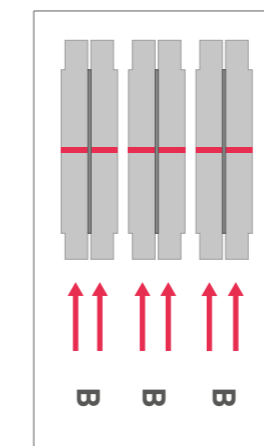

#### CONTENEDOR 40' CONTAINER 40'

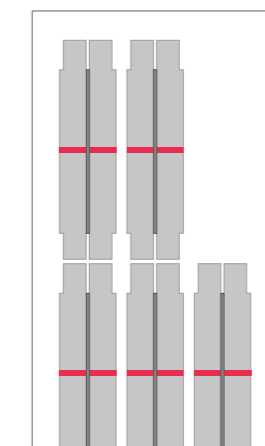

# CONTROL DE CALIDAD

QUALITY CONTROL

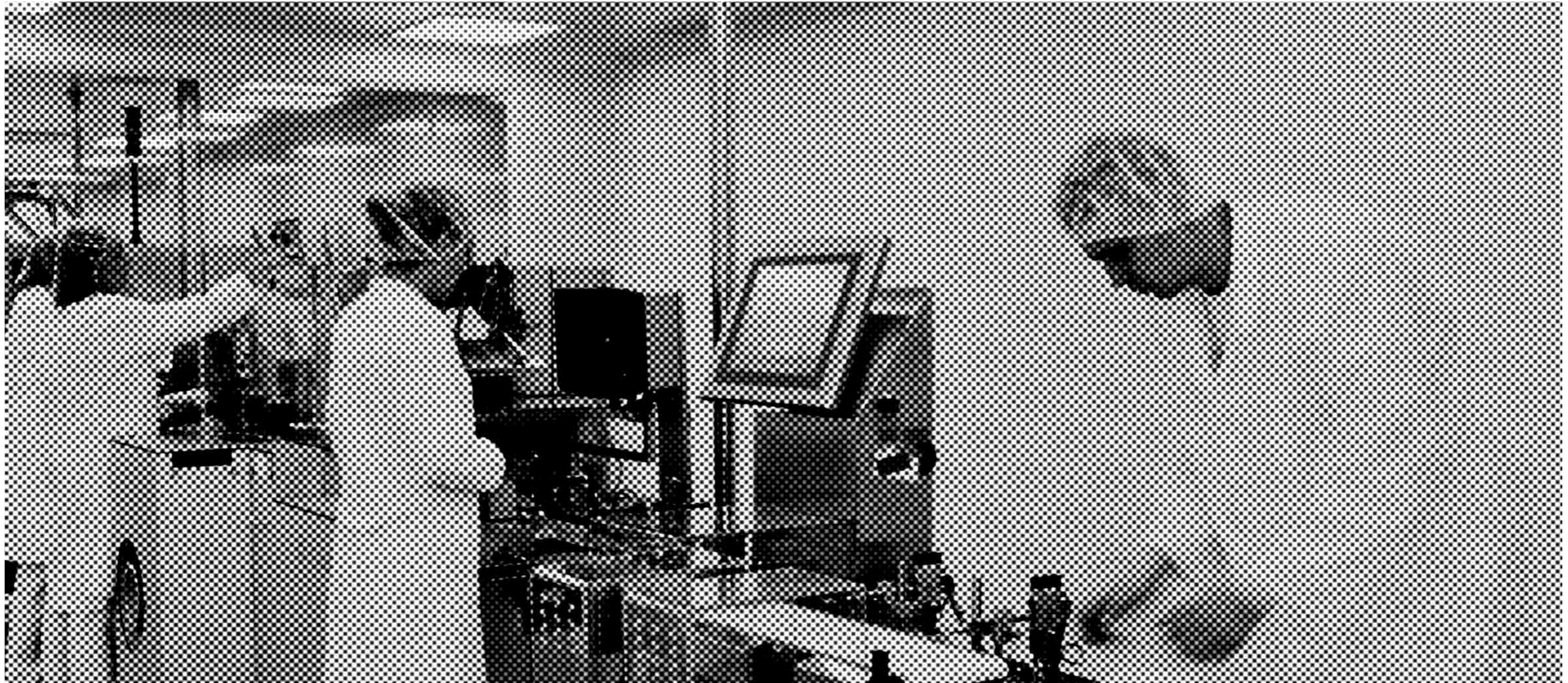

**CONTROL DE CALIDAD**

QUALITY CONTROL

**ESPESOR**

THICKNESS

Previo al proceso de mecanización, Grespania recomienda limpiar a fondo las piezas y realizar una cuidadosa inspección visual para la comprobación de todos los requisitos de calidad. Una vez instalado o fabricado no se admitirán reclamaciones de calidad.

Prior to machining, Grespania recommends a thorough clean of the pieces in addition to a careful visual examination for quality control. Once they are installed or manufactured, no quality claims can be made.

ESPESOR NOMINAL (SP) NOMINAL THICKNESS (SP)	TOLERANCIA TOLERANCE	H1 (mm)
10,5	+/-0,5	<1,3 +/-0,07
12,4	+/-0,5	<1,3 +/-0,07
20	+/-0,5	<1,3 +/-0,07



Superficie lisa Flat surface



Superficie con relieve Rough surface

**PLANEIDAD**

FLATNESS

Para medir correctamente la planaridad, la tabla debe descansar sobre un plano de referencia perfectamente horizontal y estable, por lo que no se debe usar caballetes ni realizar mediciones con la tabla suspendida. La planaridad se mide con una barra de aluminio y medidores de espesor en el centro.

Se determinará la conformidad del tablero dependiendo del espacio existente entre la parte central de la barra y el tablero.

To correctly measure for flatness, the panel should be resting on a perfectly horizontal and stable reference plane, therefore A-frame pallets should not be used, nor should measurements be taken with the panel suspended. Flatness is measured using an aluminium bar and thickness measuring devices in the centre.

Compliance is determined by the space between the centre of the bar and the panel.

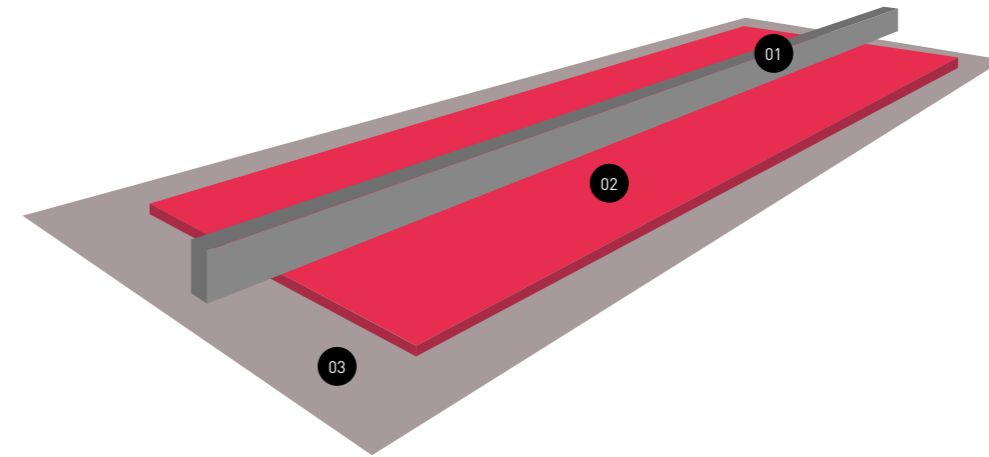

- 01 BARRA DE ALUMINIO  
ALUMINIUM BAR
- 02 COVERLAM TOP  
COVERLAM TOP
- 03 PLANO DE REFERENCIA  
REFERENCE PLANE

ESPESOR THICKNESS	TRANSVERSAL TRANSVERSAL		LONGITUDINAL LONGITUDINAL	
	ANCHO WIDTH	F (mm)	LONGITUD (mm) LENGTH	F (mm)
10,5 mm	1000	2mm	3000	2mm
12 mm	1620	2mm	3240	2mm
20 mm	1600	2mm	3200	2mm

LONGITUDINAL LONGITUDINAL



PLANEIDAD (F)  
FLATNESS

- 01 BARRA DE ALUMINIO  
ALUMINIUM BAR
- 02 COVERLAM TOP  
COVERLAM TOP
- 03 PLANO DE REFERENCIA  
REFERENCE PLANE

TRANSVERSAL TRANSVERSAL



# MECANIZADO /

## MACHINING

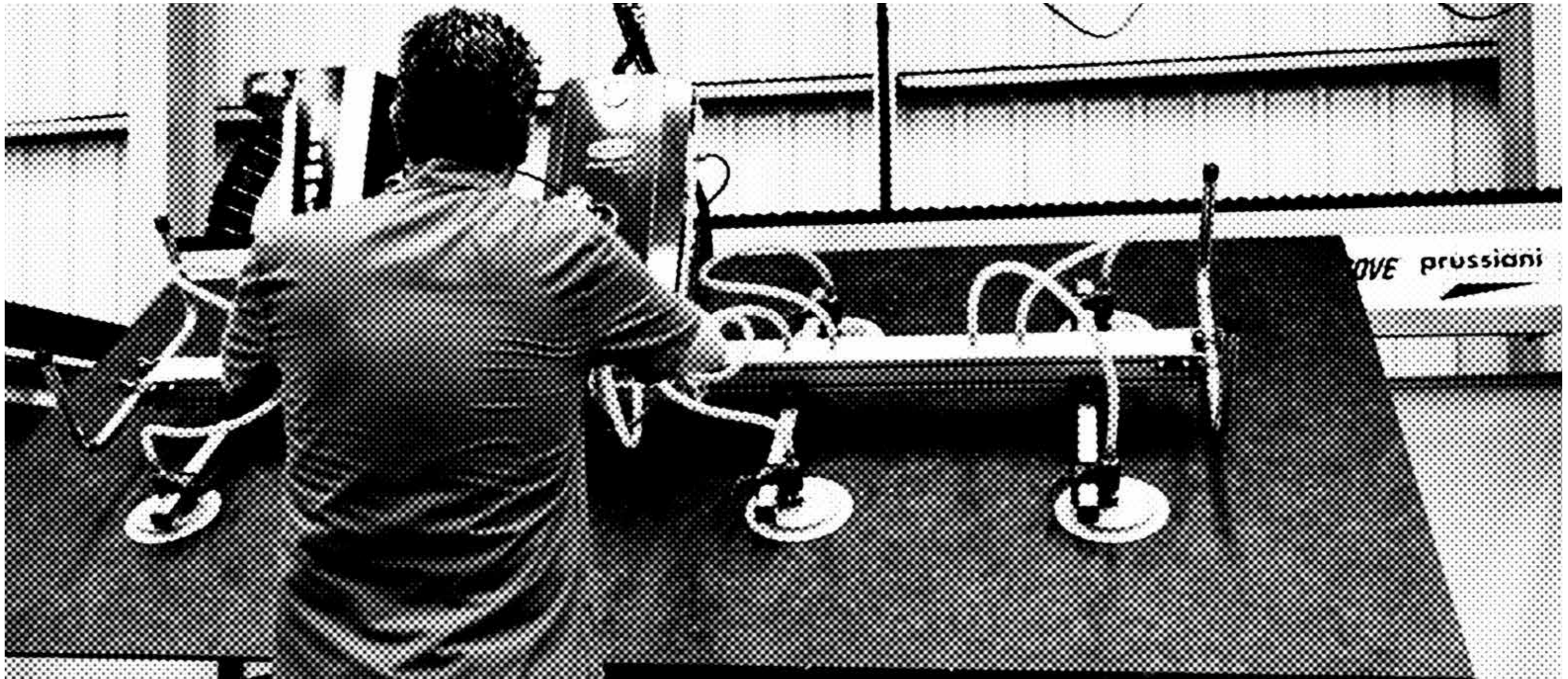

## MECANIZADO

## MACHINING

## DISCO PUENTE

## BRIDGE SAW

RECOMENDACIONES  
GENERALES /

## GENERAL RECOMMENDATIONS

Se recomienda rebajar 2 cm de cada lado de Coverlam Top para liberar tensiones internas el tablero.

Asegúrese de que la mesa de trabajo esté en buen estado y esté plana.

La dirección del corte siempre debe coincidir con la rotación del disco.

Todos los encastrés deben tener agujeros previamente perforados.

We recommend trimming 2cm off each side of the Coverlam Top to release any tension within the panel.

Make sure that the work bench is in good condition and even.

The direction of the cut should always coincide with the rotation of the cutting disk.

All inserts must have any holes predrilled.

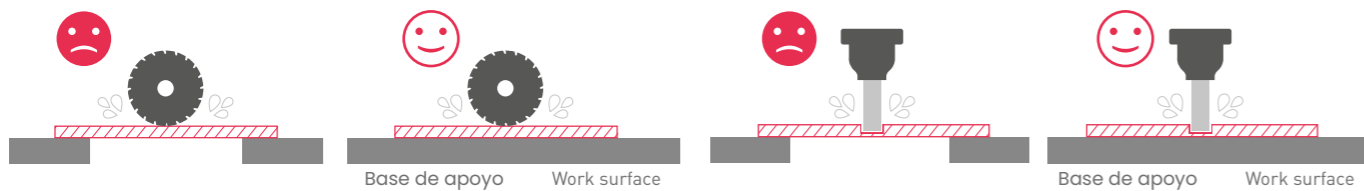

## PARAMETROS DE MECANIZADO / MACHINING PARAMETERS

ESPEJOR THICKNESS	VELOCIDAD INGLETE (M/MIN) MITRE SPEED (M/MIN)	Ø DISCO Ø DISC	RPM	VELOCIDAD DE SUPERFICIE (M/MIN) SURFACE SPEED (M/MIN)
10,5mm	0,7-1 m/min	300mm	2500	1-1,5 m/min
12mm		350mm	2200	
		400mm	1900	
20mm	0,5 m/min	400mm	2000-2150	1 m/min

## EJEMPLO DE CORTE DE FRESADORA DE PUENTE / SAMPLE CUT FOR A BRIDGE MILLING MACHINE

- 1 Cortes para liberar tensión de la pieza  
Cuts to release tension within the piece
- 2 3 Cortes de rebaje para ajustar a medidas finales de la encimera  
Recess cuts to adjust to the final countertop measurements
- 4 Cortes de encastre  
Cuts out s

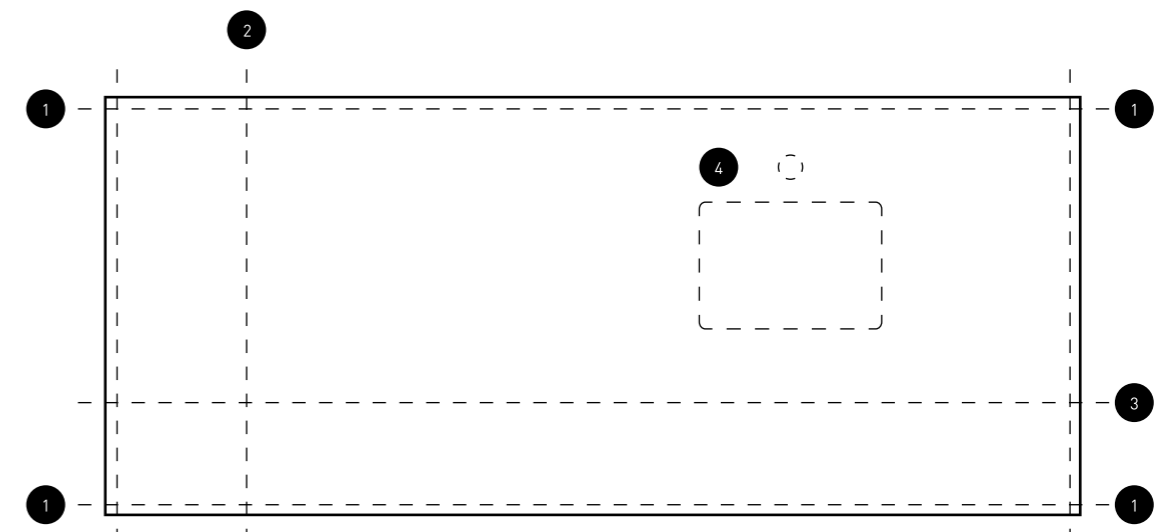

## MECANIZADO

### MACHINING

CNC

CNC

#### RECOMENDACIONES GENERALES / GENERAL RECOMMENDATIONS

Se recomienda rebajar 2 cm de cada lado de Coverlam Top para liberar tensiones internas el tablero.  
Se aconseja distribuir de forma adecuada las ventosas para sostener las zonas de la pieza sometidas a más esfuerzo durante el mecanizado.

Asegurarse de que hay ventosas por debajo de la superficie a cortar, especialmente del encastre.

We recommend trimming 2cm off each side of the Coverlam Top to release any tension within the panel.  
We recommend a suitable distribution of the sucker pads to support the parts of the piece subject to stress during machining.

Make sure that there are sucker pads beneath the cutting surface, especially that of the insert.

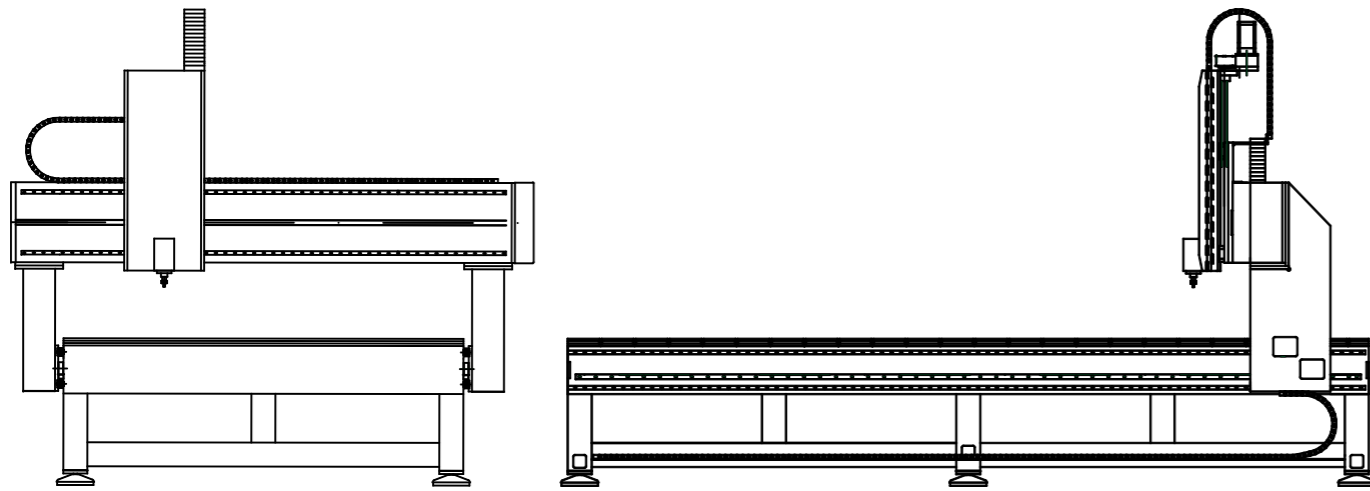

#### PARAMETROS DE MECANIZADO/ MACHINING PARAMETERS

HERRAMIENTA TOOL	RPM	VELOCIDAD (mm/min) SPEED (mm/min)
Broca de corona Crown drill bit	4500 - 5500	10
Fresolín de corte Router cutter	12"	4500 - 5500
	20"	4500 - 5500
Fresolín de rebaje Recess router	8000 - 10000	250

#### SECUENCIA DE CORTE/ CUTTING SEQUENCE

- 1- Corte Perimetral
- 2- Perforación con corona de diametro > 30mm
- 3- Cortar con fresolín partiendo del agujero realizado por la broca previamente

- 1- Perimeter cut
- 2- Drill hole using a 30mm crown core bit
- 3- Cut using a router cutter starting from the hole drilled earlier

- 1 Cortes para liberar tensión de la pieza  
Cuts to release tension within the piece
- 2 Cortes de encastre  
Cuts outs

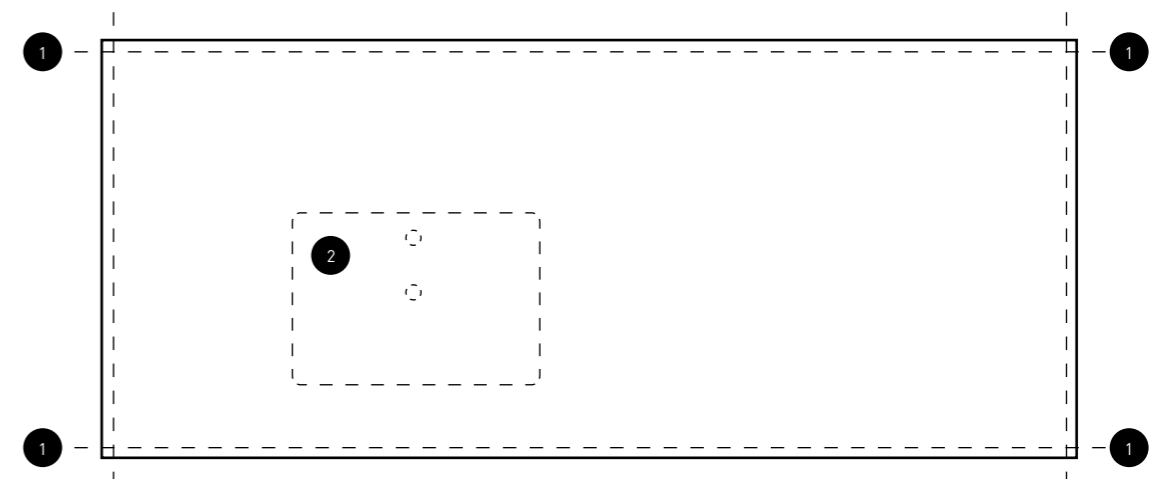

Antes de empezar la fabricación de una tabla de 20mm, 12mm o 10,5mm es importante quitar 2cm de la tabla.  
Before starting to work on a 20mm, 12mm or 10,5mm panel, it is important to trim 2cm off each side of the panel.

## MECANIZADO

## MACHINING

## CORTE POR AGUA

## WATER JET CUTTER

## RECOMENDACIONES GENERALES / GENERAL RECOMMENDATIONS

Se recomienda rebajar 2 cm de cada lado de CoverlamTop para liberar tensiones internas el tablero  
Comprobar que la bancada este nivelada y libre de cualquier escombros

We recommend trimming 2cm off each side of the Coverlam Top to release any tension within the panel.  
Check that the workbench is level and free of any debris.



## PARAMETROS DE MECANIZADO/ MACHINING PARAMETERS

ESPELOR THICKNESS	VELOCIDAD (m/min) SPEED (m/min)	PRESIÓN (Bar) PRESSURE (Bar)	ALIMENTACIÓN DE ABRASIVO (kg/min) ABRASIVE FEED RATE (kg/min)
10,5mm 12mm	1	3500 - 3700	0,4
20mm	0,7		

## SECUENCIA DE CORTE/ CUTTING SEQUENCE

- 1 Cortes para liberar tensión de la pieza  
Cuts to release tension within the piece
- 2 Corte de rebaje para ajustar a medidas finales  
Recess cuts to adjust to the final measurements
- 3 Cortes de encastrado  
Cuts outs

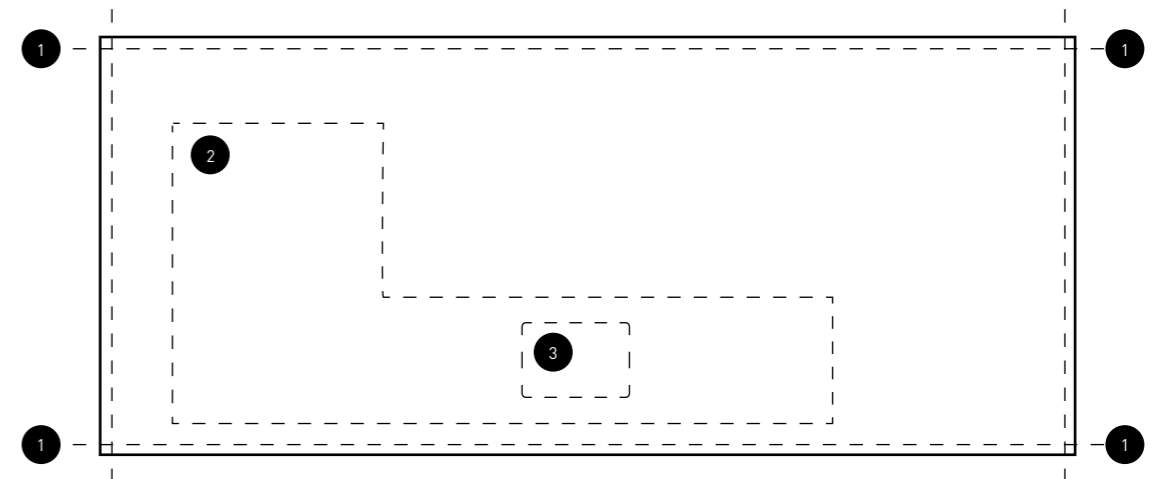

Antes de empezar la fabricación de una tabla de 20mm, 12mm o 10,5mm es importante quitar 2cm de la tabla  
Before starting to work on a 20mm, 12mm or 10,5mm panel, it is important to trim 2cm off each side of the panel.

# RECOMENDACIÓN DE DISEÑO DE ENCIMERA

COUNTER DESIGN RECOMMENDATIONS





## RECOMENDACIÓN DE DISEÑO DE ENCIMERA

### COUNTER DESIGN RECOMMENDATIONS

#### HUECOS Y ENCASTRES

##### RECESSES AND INSERTS

Para la correcta elaboración de un encastre, se recomienda taladrar primero las esquinas y después realizar los cortes perimetrales.

To correctly create the inset recess, we recommend drilling holes in the corners first and then cutting around the outer edges.



Para el taladro en las esquinas se recomienda trabajar siempre con radios de corte superiores a 3mm. La distancia mínima entre el encastre y cualquier lado de la encimera debe ser 5cm.

For drilling the holes in the corners, we recommend always using a bit with a radius of over 3mm. The minimum distance between the inserts and any edge of the countertop should be 5cm.

Para huecos de encastre, se recomienda evitar esquinas de 90°. Como norma general, se recomienda evitar un diseño de encimera que conlleve una distribución de pesos desequilibrada en la encimera terminada.

For the inset recesses, we recommend avoiding 90° angles at the corners. As a general rule, we advise against designs that result in an uneven weight distribution of the finished countertop.

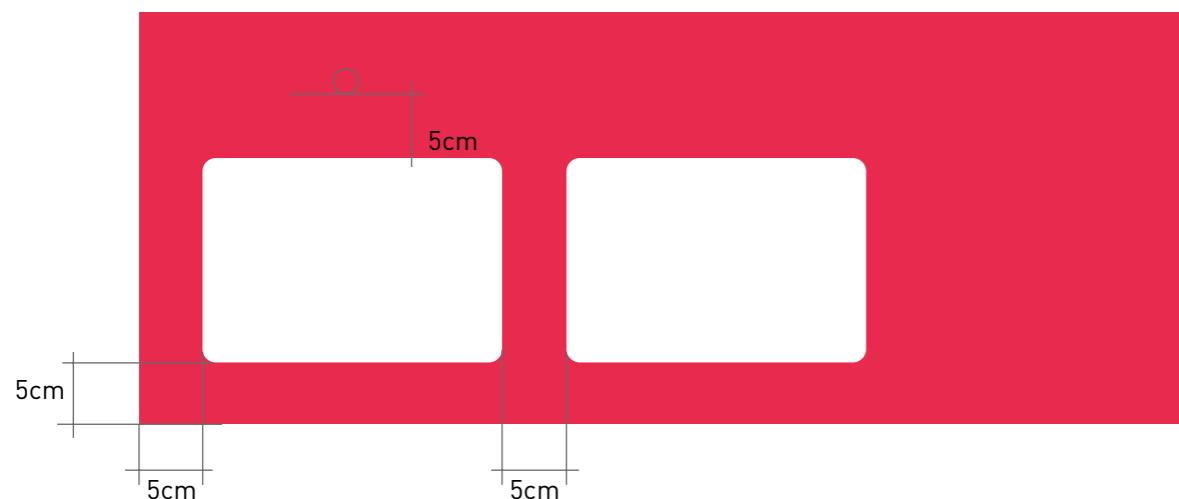

#### FREGADEROS

##### SINKS

A la hora de instalar un fregadero enrasado, se recomienda no rebajar mas de 5mm en un tablero de Coverlam Top. De cara a la instalación de fregaderos bajo encimera, se recomienda redondear ligeramente los bordes de Coverlam Top para evitar astillados. En caso de trabajar con fregaderos de grandes dimensiones, se recomienda reforzar el mueble de cocina con alguna estructura que soporte el fregadero.

When installing a flush mount sink, we advise against cutting down into the COVERLAM TOP panel by more than 5mm. When installing undermount sinks, we recommend lightly rounding off the COVERLAM TOP edges to prevent chipping. If working with large sinks, we recommend reinforcing the kitchen unit using a structural support for the sink.

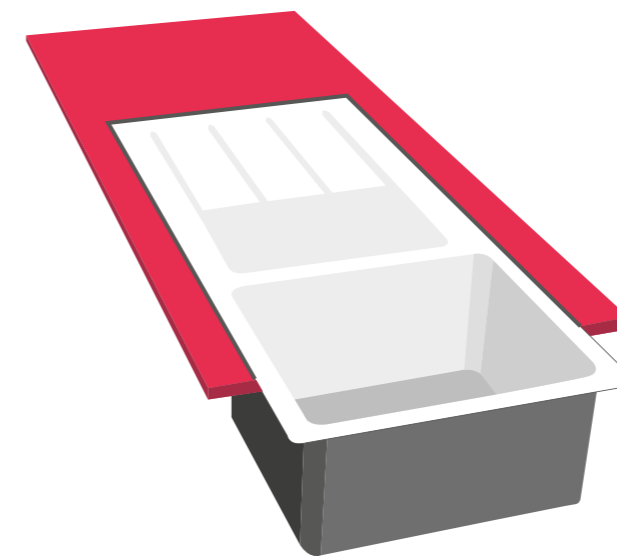

FREGADERO SOBRE ENCIMERA  
OVERMOUNT SINK

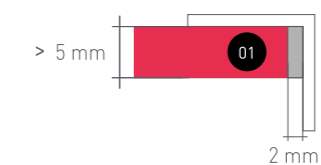

01 COVERLAM  
COVERLAM

02 SILICONA  
SILICON

FREGADERO A RAS DE ENCIMERA  
FLUSH MOUNT SINK

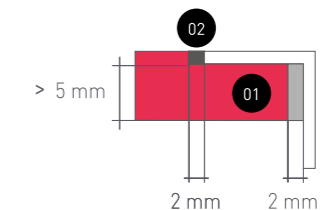

Se recomienda reforzar el mueble de cocina con alguna estructura que soporte el fregadero.  
We recommend reinforcing the kitchen unit using a structural support for the sink.

**RECOMENDACIÓN DE DISEÑO DE ENCIMERA**

COUNTER DESIGN RECOMMENDATIONS

**CANTOS Y JUNTAS**

EDGES AND JOINTS

En el caso de cantos no ingletados, se recomienda trabajar o con un canto con un radio de 2mm o con un bisel de 2mm.

With non-mitred edges, we recommend working with either a 2mm-radius edge or a 2mm bevel.



Biselado Bevelled



Pulido Polished



Biselado Bevelled



Pulido Polished



Inglete Mitre

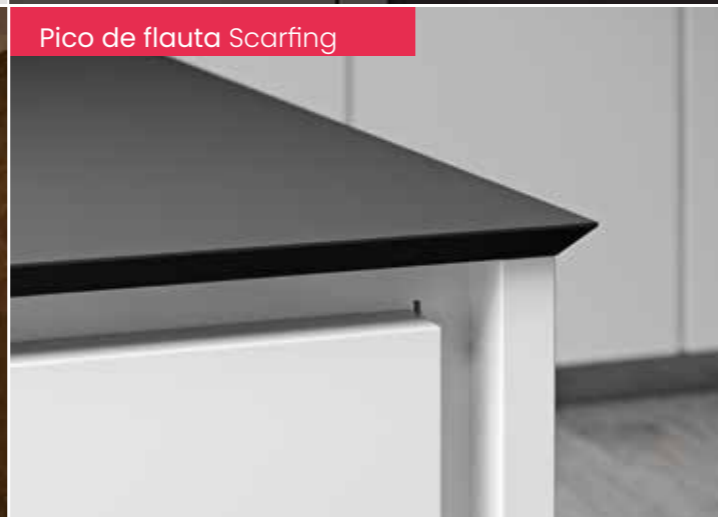

Pico de flauta Scarfing

**VOLADIZOS**

OVERHANGS

	ESPEORES THICKNESSES			ILUSTRACIÓN ILLUSTRATION
	10,5 mm	12 mm	20 mm	
Encimera con voladizo sin soporte Countertop with unsupported overhangs	X ≤ 300 mm	X ≤ 350 mm	X ≤ 500 mm	
Encimera con orificio y voladizo sin soporte Countertop with recess and unsupported overhang	X ≤ 300 mm	X ≤ 350 mm	X ≤ 500 mm	

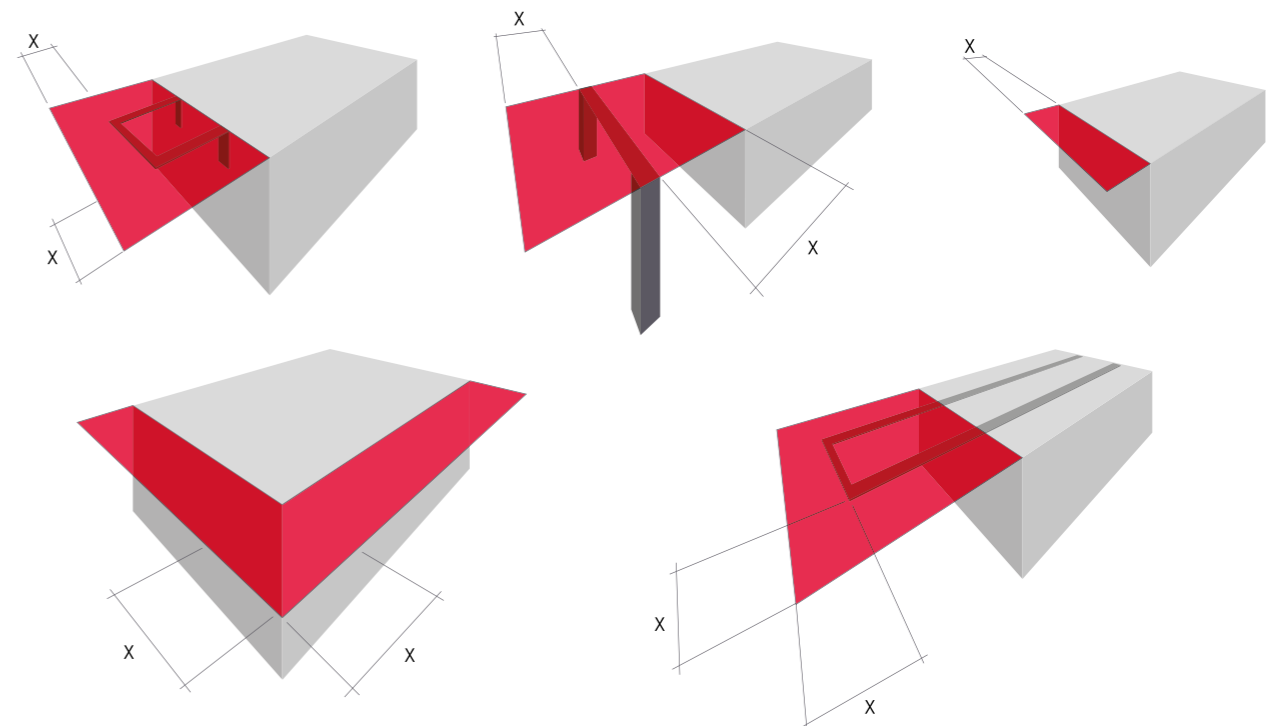

## RECOMENDACIÓN DE DISEÑO DE ENCIMERA

### COUNTER DESIGN RECOMMENDATIONS

#### INSTALACIÓN DE ENCIMERAS / COUNTERTOP INSTALLATION

De cara a la instalación de la encimera terminada sobre el mueble de cocina, los muebles deben estar correctamente nivelados, fijados entre ellos y fijados a la pared..

When installing the finished countertop on top of a kitchen unit, the units should be properly levelled, fixed together and anchored to the wall.

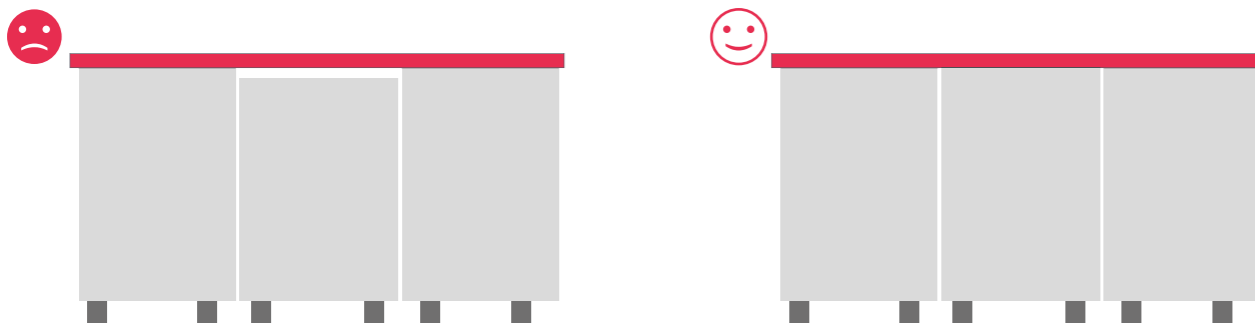

En caso de instalar próxima a una placa de vitrocerámica, se recomienda dejar una distancia mínima entre la encimera y la vitrocerámica de 2mm.

Es necesario dejar una junta perimetral de 3 mm en la encimera con el fin de absorber las irregularidades de la pared y los movimientos del edificio

When installing in close proximity to a vitro-ceramic hob, we advise leaving a minimum distance of 2mm between the countertop and the hob.

The countertop requires a 3mm perimeter joint to compensate for any irregularities in the wall or building movements.

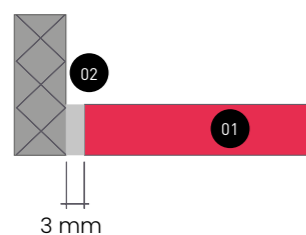

01 COVERLA M  
COVERLAM

02 SILICONA  
SILICON

Se recomienda utilizar un adhesivo flexible para el rellenado de juntas o la fijación de la encimera al mueble de cocina, de tal forma que presente un comportamiento ante la expansión térmica aceptable.

We recommend using a flexible adhesive to fill joints and bind the countertop to the kitchen unit so that it performs adequately should thermal expansion occur.



#### OTROS

#### OTHERS

#### REFUERZOS / REINFORCING

En caso de trabajar con bordes ingletados, estos deben estar reforzados con listones de CoverlamTop. Se desaconseja trabajar con refuerzos de otro material por la diferencia en la expansión térmica y por las patologías que esta puede generar en la encimera (Curvatura, apertura del canto ingletado). Se recomienda reforzar los perímetros del encastre para dar mas solidez a la unión.

When working with mitred edges, these should be reinforced using CoverlamTop strips. We advise against using reinforcements made from other materials due to the differences in thermal expansion and any repercussions that this might have on the countertop (curvature, opening of the mitred edge). We recommend reinforcing the perimeters of the inserts to make the join more solid.

#### EXTERIORES / EXTERIORS

En caso de tratarse de una encimera de exteriores, se recomienda instalar CoverlamTop sobre materiales con coeficientes de dilatación similares (Cemento o ladrillo)

Se desaconseja la instalación de CoverlamTop sobre soportes de madera por la tendencia a expandir de dichos materiales en exteriores y las patologías asociadas que ello conlleva.

Como adhesivo de exteriores se recomienda emplear adhesivos cementosos mejorados tipo C2.

For an exterior countertop, we recommend installing CoverlamTop on materials with similar expansion coefficients (cement or brick).

We advise against installing CoverlamTop on top of a wooden base given their tendency to expand outdoors and any repercussions that this might have.

For exterior adhesives, we recommend using C2 improved cementitious adhesive.



# HERRAMIENTAS

TOOLS



## HERRAMIENTAS

## TOOLS

## RECOMENDACIONES

## RECOMMENDATIONS

Grespania recomienda el uso de herramientas FREDIMAR para un correcto mecanizado de CoverlamTop:

Grespania recommends the use of FREDIMAR tools for the correct machining of CoverlamTop:



Disco segmentado para corte de todo tipo de materiales porcelánicos.  
Tanto para corte a 90° como para corte a inglete a 45°.  
Altura diamantada de 10mm

Segmented blade for cutting all types of porcelain materials.  
Both for 90-degree cuts and 45-degree mitre cuts. 10mm diamond height.



Fresolín segmentado (CNC)

Segmented router bit (CNC)



Corona con diamante electrodepositado (CNC)

Electroplated diamond core drill bit(CNC)



Broca diamantada para taladrar con agua y a alta velocidad

Diamond drill bit for water jet drilling and at high speed



Corona continua

Continuous core drill bit



Lijas de granas variables para el pulido final de cantos

Sandpaper with a range of different grits for final polishing of edges

# PEGADO

BONDING

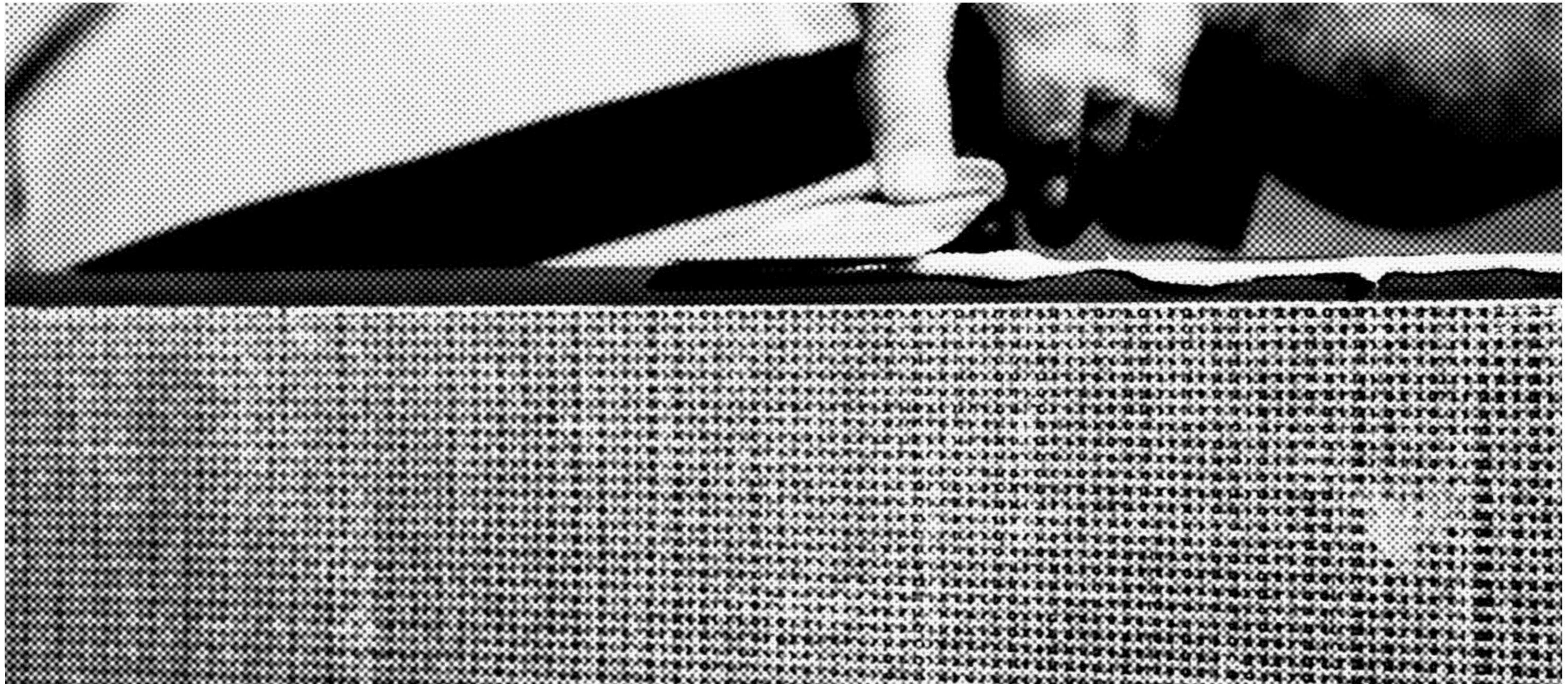

## PEGADO

## BONDING

## ADHESIVOS RECOMENDADOS

## RECOMMENDED ADHESIVES

Grespania recomienda el uso de adhesivos AKEMI para las distintas necesidades de pegado con CoverlamTop. Para garantizar la correcta adhesión de las juntas en función del destino final de la encimera es necesario emplear un adhesivo de la siguiente selección de productos:

Grespania recommends the use of AKEMI adhesives for different bonding requirements with CoverlamTop. To ensure the correct adhesion of the joints according to the intended use for the countertop, one of the following ranges of adhesives should be used:

**PLATINUM/ PLATINUM**

La gama de adhesivos Platinum consiste en un pegamento de máxima calidad en base epoxi acrilato 2 componentes, de consistencia gelatinosa (transparente ligeramente opaco) y líquida (transparente claro) muy adecuado para trabajos en vertical y horizontal gracias a sus distintas consistencias. Muy fácil de colorear con colorantes poliéster Akemi. Excelentes resultados de pulido.

Presentación en botes de 900 ml (caja de 6 unidades)

The Platinum range consists of top-quality two-component adhesives based on epoxy acrylate. The two different consistencies, gel-like (transparent and slightly opaque) and liquid (clear transparent), make it very suitable for both vertical and horizontal jobs. Very easy to colour with Akemi polyester colouring pastes. Excellent polishing results. Available in 900 ml cans (packs of 6)

**COLOUR BOUND / COLOUR BOUND**

Es un producto gelatinoso de dos componentes, a base de resinas epoxi acrilato diluidas en estireno. Muy buena aplicación debido a su consistencia muy suave y ligeramente gelatinosa, no deja hilachas. Endurecimiento muy rápido (15 a 40 minutos), muy buen pulido, resistente al agua, la gasolina y a los aceites minerales. Amplia gama de colores, más de 50 colores que permiten realizar el pegado de juntas invisibles. Presentación en cartuchos de 250 ml (caja de 6 unidades)

A gel-like two-component product based on epoxy acrylate resins dissolved in styrene. Very workable due to its very smooth, slightly gel-like consistency - does not form filaments. Very fast hardening (15 to 40 minutes), very good polishing, resistant to water, petrol and mineral oils. Wide range of colours; more than 50 colours enables invisible joints. Available in 250 ml cartridges (packs of 6)

**AKEPOX / AKEPOX**

Akepox5000 y Akepox5010 son dos sistemas de 2 componentes a bases de resina epoxi resistente frente a los rayos UV.

Este sistema de pegado de alta calidad ha sido especialmente desarrollado para su uso en el exterior, es resistente a la intemperie y casi no amarillea. Están recomendados para el pegado de juntas visibles.

idóneo para teñir con colorantes Akepox, apto para pulir, muy poco encogimiento durante el proceso de secado, sin disolvente, por su consistencia cremosa es adecuado para trabajos verticales.

Una vez endurecido el producto, no es nocivo para la salud en contacto con los alimentos.

Presentación en botes y Cartuchos



Akepox5000 and Akepox5010 are both two-component adhesive systems based on an epoxy resin that is resistant to UV rays. This high-quality adhesive system has been specially developed for outdoor use: it is weather-resistant and has a low tendency to yellowing. It is recommended for creating invisible joints, and is ideal for colouring with AKEPOX colouring pastes. It is suitable for polishing, has very low shrinkage during hardening, and is solvent-free. Its creamy consistency makes it suitable for vertical jobs.

Once the product hardens, it is not harmful to human health when it comes in contact with food.

Available in cans and cartridges.

# LIMPIEZA /

STAIN





## MANUAL DE LIMPIEZA

## STAIN GUIDE

Coverlam Top presenta una resistencia al manchado excepcional gracias a su casi nula porosidad, lo cual permite que gran parte de los residuos generados durante el uso cotidiano de la encimera no penetren en el material. Asimismo, y gracias a la textura suave de su superficie, Coverlam Top es un material fácil de limpiar y presenta requisitos muy exigentes en cuanto a productos o útiles de limpieza.

Coverlam Top boasts exceptional stain resistance as it is virtually non-porous, which means that a large part of the waste produced during daily use of the countertop does not penetrate the material. Moreover, thanks to its smooth surface, Coverlam Top is an easy material to clean, and has very specific requirements in terms of cleaning products and tools.

## LIMPIEZA COTIDIANA

## DAILY CLEANING

Para la limpieza cotidiana de Coverlam Top se recomienda el uso de agua caliente, con detergente en la dosis de uso recomendado por el fabricante, siempre y cuando no contenga Ácido Fluorhídrico.

Enjuagar con agua tibia y secar con un paño.

En caso de que se derramen líquidos, se recomienda limpiarlos lo antes posible para evitar que la mancha seque y sea más difícil de limpiar.

Se desaconseja el uso de jabones con contenido en ceras o la aplicación de tratamientos hidrorrepelentes, ya que el uso de estos productos puede dejar una película aceitosa en la superficie de Coverlam Top que puede alterar su apariencia estética.

Hot water is recommended for the daily cleaning of Coverlam Top. Detergent can be added to the water at the manufacturer-recommended dose, provided it does not contain hydrofluoric acid.

Rinse with warm water and dry with a cloth.

Any spilt liquids should be cleaned immediately to stop the stain to dry out and thus, making the stain more difficult to clean.

Soaps that contain wax and water-repellent treatments are not recommended, as these products may leave an oily film on the surface of Coverlam Top, which can affect its aesthetic appearance.

## LIMPIEZA EXTRAORDINARIA

## SPECIAL CLEANING

En caso de que la limpieza ordinaria sea insuficiente para eliminar alguna mancha, hay que seguir otros procedimientos y utilizar productos de limpieza específicos según la naturaleza de la mancha.

Se recomienda iniciar la limpieza en una zona reducida para comprobar su eficacia antes de extender el producto en el resto de la superficie.

Grespania colabora estrechamente con el fabricante de adhesivos y productos de limpieza AKEMI. Para la consulta de información detallada sobre los tratamientos específicos para cada mancha en función de su naturaleza, se recomienda seguir la tabla facilitada donde se detallan diferentes tipos de manchas posibles y los productos de limpieza AKEMI más adecuados para eliminarlas:

For any stains that cannot be removed with regular cleaning, certain procedures should be followed and specific cleaning products should be used, depending on the type of stain.

It is advisable to clean a small area first to check the effectiveness of a product before using it on the rest of the surface.

Grespania works closely with AKEMI, a manufacturer of adhesives and cleaning products, to provide advice on the specific treatments for each type of stain. It is advisable to refer to the table below that lists different types of stains and the most suitable AKEMI cleaning products for removing them:

No utilizar en ningún caso ácido clorhídrico o sosa cáustica concentrada, ni tampoco productos que contengan ácido fluorhídrico y sus derivados.

Si necesita información sobre dónde comprar los productos AKEMI, póngase en contacto con su comercial de Coverlam Top de su zona.

Under no circumstances should concentrated hydrochloric acid or caustic soda be used, nor products that contain hydrochloric acid or derivative products. For additional information regarding Akemi products, please contact your Coverlam Top Sales Representative.

SUCIERDAD / STAINS	SOLUCIÓN AKEMI/ AKEMI SOLUTION	SUCIERDAD / STAINS	SOLUCIÓN AKEMI/ AKEMI SOLUTION
Cinta adhesiva /Masking tape	● Acryclean / Acryclean	Restos de adhesivos y resinas Residues of fillers and resins	● Acryclean/ Acryclean
Marcas metálicas producidas por herramientas o utensilios de cocina Metallic marks caused by kitchen tools or utensils	● Eliminación de capas finas de cemento Concrete film remover	Tinta de bolígrafo Ball-pen tint	● Limpieza básica /Stone Cleaner ◇ Intensive Cleaner/ Intensive Cleaner
Bayas /Berries	● Anti-musgo y algas power Algae and moss remover power	Laca/ Paint	● Eliminación de Graffiti /Graffiti Remover
Lápiz/Pencil marks	● Limpieza básica /Stone cleaner ◇ Intensive cleaner/ Intensive cleaner	Lápiz de labios Lipstick	● Limpieza básica /Stone Cleaner ◇ Intensive Cleaner/ Intensive Cleaner
Manchas causadas por flores Blossom stains	● Anti-musgo y algas power Algae and moss remover power	Restos de alimentos (incrustaciones) Food stains (encrustations)	● Limpieza básica/Stone Cleaner
Sangre /Blood	● Anti-musgo y algas power Algae and moss remover power ◇ Limpieza básica /Stone cleaner	Maggi /Maggi	● Anti-Musgo y Algas POWER Algae and Moss Remover POWER ◇ Limpieza básica/Stone Cleaner
Pintura fresca de dispersión Fresh emulsion paint	● Limpieza básica y agua caliente Stone cleaner and warm water	Mermelada /Jam / marmelade	● Limpieza básica /Stone Cleaner
Helado /Ice cream	● Limpieza básica /stone cleaner ◇ Intensive cleaner/ Intensive cleaner	Restos de mortero Traces of mortar	● Eliminación de capas finas de cemento Concrete Film Remover ◇ Acid Cleaner/ Acid Cleaner ◇ Limpieza básica /Stone Cleaner
Capas finas de epoxi Residues of epoxy resin	● Eliminación de epoxi Epoxy remover	Esmalte de uñas /Nail varnish	● Acryclean/ Acryclean
Grasa /Fat	● Limpieza básica /stone cleaner ◇ Intensive cleaner/ Intensive cleaner	Nutella Nutella	● Pasar un paño, limpieza básica Wipe roughly, stone cleaner ◇ Acryclean/ Acryclean
Rotulador / Felt-tip pen	● Intensive cleaner ◇ Acryclean/ Acryclean	Manchas causadas por plantas, hojas, flores Organic discoloration caused by leaves and blossoms	● Anti-Musgo y Algas POWER Algae and Moss Remover POWER
Fruta /Fruit	● Anti-musgo y algas power Algae and moss remover power	Restos de productos de cuidado / capas de brillo Care product residues/ self-shining coatings	● Limpieza básica /Stone Cleaner ◇ Intensive Cleaner/ Intensive Cleaner
Zumos de fruta (decoloraciones) Fruit juice (discoloration)	● Anti-musgo y algas power Algae and moss remover power	Productos de limpieza (restos / capas) Cleaning agent (residues / layers)	● Acid Cleaner/ Acid Cleaner ● Intensive Cleaner/ Intensive Cleaner
Limpieza de fugas Cleaning of joints	● Limpieza básica /stone cleaner ◇ Intensive cleaner/ Intensive cleaner	Óxido Rust	● Superficies horizontales, desoxidación Horizontal surfaces, rust remover ● Superficies verticales, pasta de desoxidación Vertical surfaces, rust remover paste
Taninos Tanning agent	● Anti-musgo y algas power Algae and moss remover power	Hollín Soot	◇ Limpieza básica /Stone Cleaner ● Intensive Cleaner/ Intensive Cleaner
Verduras Tanning agent	● Anti-musgo y algas power Algae and moss remover power	Vino tinto Red wine	● Anti-Musgo y Algas POWER Algae and Moss Remover POWER
Especies Spices	● Anti-musgo y algas power Algae and moss remover power ◇ Limpieza básica /Stone cleaner	Betún Shoe polish	limpiar previamente con papel de cocina, después ● Acryclean/ Acryclean ◇ Limpieza básica /Stone Cleaner
Manchas orgánicas Organic layers	● Anti-musgo y algas power Algae and moss remover power	Manchas de moho Mildew / mold stains	● Anti-Musgo y Algas POWER Algae and Moss Remover POWER
Graffiti Graffiti	● Eliminación de graffiti Graffiti remover	Jabones Soap	● Agua caliente y limpieza de sanitarios Hot water and disinfectant cleaner ◇ Eliminación de incrustaciones de orina y cal Urine scale and lime scale remover
Manchas de césped (decoloraciones) Grass stains (discoloration)	● Anti-musgo y algas power Algae and moss remover power	Restos de silicona, adhesivos elásticos Residues of silicone, elastic adhesives	● Acryclean/ Acryclean
Manchas de goma (zapatos, llantas) Rubber „skid“ marks (shoe soles, car tyres)	◇ Limpieza básica /stone cleaner ● Intensive cleaner/ Intensive cleaner	Pinturas spray Colour sprays	● Eliminación de Graffiti Graffiti Remover
Gel para el cabello Hair gel	● Limpieza básica /stone cleaner ◇ Intensive cleaner/ Intensive cleaner	Almohadilla de tinta Ink-pad tint	● Eliminación de Graffiti Graffiti Remover ◇ Acryclean/ Acryclean ◇ Intensive Cleaner/ Intensive Cleaner
Spray para el cabello / Hair spray	● Acryclean/ Acryclean	Té Tea	● Anti-Musgo y Algas POWER Algae and Moss Remover POWER
Resina de árboles/ Tree resin	● Acryclean/ Acryclean	Tinta Ink	● Anti-Musgo y Algas POWER Algae and Moss Remover POWER
Yodo Iodine	● Anti-musgo y algas power Algae and moss remover power	Productos de cuidado a base de cera Waxy care products	● Disolvente / Wax Stripper ◇ Intensive Cleaner / Intensive Cleaner
Café Coffee	● Anti-musgo y algas power Algae and moss remover power	Cera, lápiz de cera / Waxes, wax crayon	● Disolvente / Wax Stripper
Restos de cal Limestone scale	● Limpieza de sanitarios Disinfectant cleaner ◇ Eliminación de incrustaciones de orina y cal Urine scale and lime scale remover ◇ Acid cleaner/ acid cleaner	Capas finas de cemento Cement film	● Acid Cleaner / Acid Cleaner ◇ Eliminación de capas finas de cemento Concrete Film Remover ◇ Limpieza básica /Stone Cleaner
Cacao Cocoa	● Limpieza básica /Stone cleaner ◇ Anti-musgo y algas power Algae and moss remover power		
Cartones mojados Wet cartons	● Anti-musgo y algas power Algae and moss remover power		
Cera de velas Candle wax	● Raspar superficialmente, después disolvente, trabajar eventualmente con compresas Scrape off, then wax stripper, where required apply compress ● Acryclean / Acryclean		

● = mejor solución ◇ = solución alternativa  
● = best solution ◇ = alternative solution

# CERTIFICADOS Y GARANTÍA

CERTIFICATES AND WARRANTY



## CERTIFICADOS Y GARANTÍA

### CERTIFICATES AND WARRANTY



#### BIM Technology

Coverlam Top ha lanzado una serie de productos como objetos BIM en la Nube de BIMobject®. Los productos están disponibles en Revit como sistemas de familias con texturas y en ArchiCAD como un elemento de recubrimiento de encimeras.

BIM es la abreviatura de Modelo de la Información de Edificios (Building Information Modeling). A partir de este modelo de información centralizada, arquitectos y consultores pueden trabajar juntos, compartir datos, comprobar las incoherencias y mejorar la colaboración. Todos los dibujos son, básicamente, una salida automática del modelo de información, todos los planos, secciones y alzados se generan automáticamente y se mantienen actualizados en todo momento.

Coverlam Top has launched a series of products on the BIMobject® cloud. Grespania has become the first Spanish tile manufacturer offering this facility. The objects are available in Revit as family systems with textures and in ArchiCAD as and in ArchiCAD as a kitchen countertop element.

BIM or 'Building Information Modeling' uses centralised pooled information as a product model to enable architects and consultants to work together, share data, check for inconsistencies, clashes and better work together. All drawings are basically an automatic output from the information model; all plans, sections & elevations are generated automatically and are kept updated all the time.



#### RIBA

Coverlam Top forma parte de RIBA (Royal Institute of British Architects) una organización profesional de arquitectos del Reino Unido con más de 40.000 miembros, entre los cuales se encuentran algunos de los arquitectos más prominentes de los últimos años. Dentro de los múltiples objetivos de RIBA, se encuentran la divulgación y formación, objetivos en los que Coverlam Top colabora a través de sus módulos CPD (Continuous Professional Development).

Coverlam Top is a member of RIBA (the Royal Institute of British Architects) an association of professional architects based in the United Kingdom with over 40,000 members, including some of the most prominent architects of the past 100 years. One of the many aims of RIBA is dissemination and training, aims that Grespania collaborates with through its Continuous Professional Development (CPD) modules.



#### ISO 14001

Coverlam Top cuenta con un sistema de gestión ambiental estructurado y certificado según directrices de la norma ISO 14001, sometido a auditorías externas realizadas anualmente, que permite identificar, evaluar y minimizar el impacto de la actividad productiva en el entorno.

Coverlam Top has an environmental management system structured and certified strictly according to the guidelines set by ISO 14001. This system is subject to yearly external audits that detect, evaluate and minimise the effect the production activity may have on the environment.



#### ISO 9001

Coverlam Top dispone de un sistema de calidad acorde con las especificaciones establecidas en la norma internacional UNE EN ISO 9001, la cual establece los requisitos necesarios para garantizar la calidad en las etapas de diseño, desarrollo, producción y comercialización.

Coverlam Top has implemented a Quality System according to the UNE EN ISO 9001 International regulation, which sets the requirements to guarantee quality during the stages of design, development, production and sales.

## CERTIFICADOS Y GARANTÍA

### CERTIFICATES AND WARRANTY

#### GARANTÍA

**Grespania, S.A.** garantiza las láminas de gres porcelánico CoverlamTop con espesores de 20, 10,5 y 12 mm contra los posibles defectos de fabricación durante 10 años desde la fecha de compra y en su uso para encimeras de cocina.

Esta garantía supone que Grespania, S.A. está obligada a sustituir la lámina defectuosa por otra similar del mismo modelo y características. En caso de que cuando se solicite la aplicación de la garantía la lámina objeto de la misma, debido al trascurso del tiempo, haya sido retirada del catálogo de Grespania, se sustituirá por otra de un modelo similar del mismo rango de espesor, precio y características.

Esta garantía es válida durante los 10 años siguientes a la fecha de la compra, debiendo el solicitante de la aplicación de la garantía plantear la oportuna reclamación por escrito dentro del citado plazo. Para ello deberá, previamente y dentro de los 30 días siguientes a la compra, solicitar el oportuno certificado de garantía a través del distribuidor o negocio donde hubiera adquirido la citada lámina, presentando a estos efectos la factura de compra y justificando el pago de la misma. La garantía no tendrá vigencia en caso de que el adquirente de la lámina no haya satisfecho el precio total de la misma.

Esta garantía supone la obligación por parte de Grespania, S.A. del suministro estricto de una lámina en sustitución de la defectuosa y siempre que se trate de un defecto de producción, no considerándose como tales las posibles diferencias de color o tono. Dado que Grespania, S.A. no realiza los trabajos posteriores para la finalización de la encimera sino que simplemente suministra la lámina, no quedan cubiertos por esta garantía los daños causados en la lámina por el transporte, la manipulación, la elaboración o la instalación de la misma.

Esta garantía excluye expresamente la instalación del producto en usos diferentes de las encimeras de cocina, tales como pavimentación, revestimiento de exteriores, etc.

Exclusiones:

Quedan excluidos de la presente garantía los daños causados por los siguientes conceptos:

- Incorrecta manipulación, elaboración y colocación del producto.
- Daños derivados del uso cotidiano que puedan presentar ligeros desperfectos derivados del mismo tras un período prolongado (arañazos, golpes, suciedad, etc.)
- Daños causados por movimientos estructurales del soporte o del edificio donde se haya instalado, así como los defectos provocados en diseños arquitectónicos, actos de vandalismo, accidentes o situaciones catastróficas.
- Daños causados por choques con objetos contundentes que puedan causar grietas o desportillados.
- Daños causados por la limpieza con elementos agresivos (cepillos, estropajos metálicos, etc.)
- Daños causados por la exposición a elementos químicos altamente corrosivos (ácido fluorhídrico, agua regia, etc.)
- Ensuciamiento de la placa debido al adhesivo, masilla, etc, utilizado en su instalación o posteriormente a ésta.
- Manipulaciones y/o reparaciones efectuadas sin tener en cuenta las recomendaciones contenidas en el manual de instalación y uso de Grespania, S.A.

#### WARRANTY

Grespania, S.A. warrants 10,5mm, 12mm and 29mm-thick Coverlam Top porcelain tile slabs against possible manufacturing defects for a period of ten (10) years from the date of purchase, when used as kitchen countertops. Under the terms of this warranty, Grespania, S.A. must replace any defective slab with another of the same model and characteristics. In the event that the slab which is the subject of the claim has been discontinued by the time the warranty claim is made, it will be replaced by another model that is similar in terms of thickness, price and other characteristics.

This warranty is valid for a period of ten (10) years from the date of purchase, and the party making the warranty claim must file an appropriate written request within the said period. To do so, the claimant must first, within thirty (30) days of the purchase, request the appropriate certificate of warranty from the distributor or company from which the slab was purchased, presenting the purchase invoice and corresponding proof of payment. The warranty will be voided if the buyer has not paid for the slab in full.

Under the terms of this warranty, Grespania, S.A. must supply one slab ONLY to replace the defective slab, provided the defect occurred during the manufacture of the product. Differences in colour or shade are not considered manufacturing defects. Given that Grespania, S.A. does not carry out post-sale installation of the countertops but merely supplies the slab, this warranty does not cover any damage caused to the slab during transport, handling, preparation or installation.

This warranty expressly excludes the installation of the product for uses other than kitchen countertops, such as paving, exterior cladding, etc.

Exclusions:

This warranty does not cover damages caused by any of the following:

- Incorrect handling, preparation and installation of the product.
- Everyday use that, after an extended period of time, may result in slight imperfections [scratches, knocks, marks, etc.]
- Structural movements of the support or building where the product has been installed, as well as defects caused by architectural designs, acts of vandalism, accidents or disasters.
- Knocks from blunt objects that can cause cracks or chips.
- Cleaning with abrasive materials (brushes, metal scourers, etc.)
- Exposure to highly corrosive chemicals (hydrofluoric acid, aqua regia/nitrohydrochloric acid etc.)
- Marking of the tile due to adhesive, putty, etc. used during or after installation.
- Any handling and/or repairs carried out that do not respect the recommendations outlined in the manual on installation and use provided by Grespania, S.A.

COVERLAMITOP

GRESPANIA



## **GRESPANIA**

**3º EDICIÓN**

**GRESPANIA S.A.**

**CV-16 Ctra. Castellón-Alcora Km.2,200**

**P.O. BOX 157 / 12080 CASTELLÓN - SPAIN**

**Tlf. +34 964 344 411**

**Fax +34 964 344 401**

**mail@grespania.com**

**www.grespania.com**

GRESPANIA S.A DISPONE DE UN SISTEMA DE GESTIÓN CERTIFICADO DE ACUERDO A LAS NORMAS ISO 9001:2015 CERTIFICADO Nº 44 100 127697 E ISO 14001:2015 CERTIFICADO Nº 44 104 127697 EN SUS PLANTAS DE NULES, MONCOFAR Y CASTELLON

GRESPANIA S.A. USES A MANAGMENT SYSTEM WITHIN ITS' FACILITIES OF NULES, MOCOFAR AND CASTELLÓN IN ACCORDANCE WITH ISO 9001:2015 CERTIFICATE Nº 44 100 127697 AND ISO 14001:2015 CERTIFICATE Nº 44 104 127697

**MAYO 2022**

**MAY 2022**